

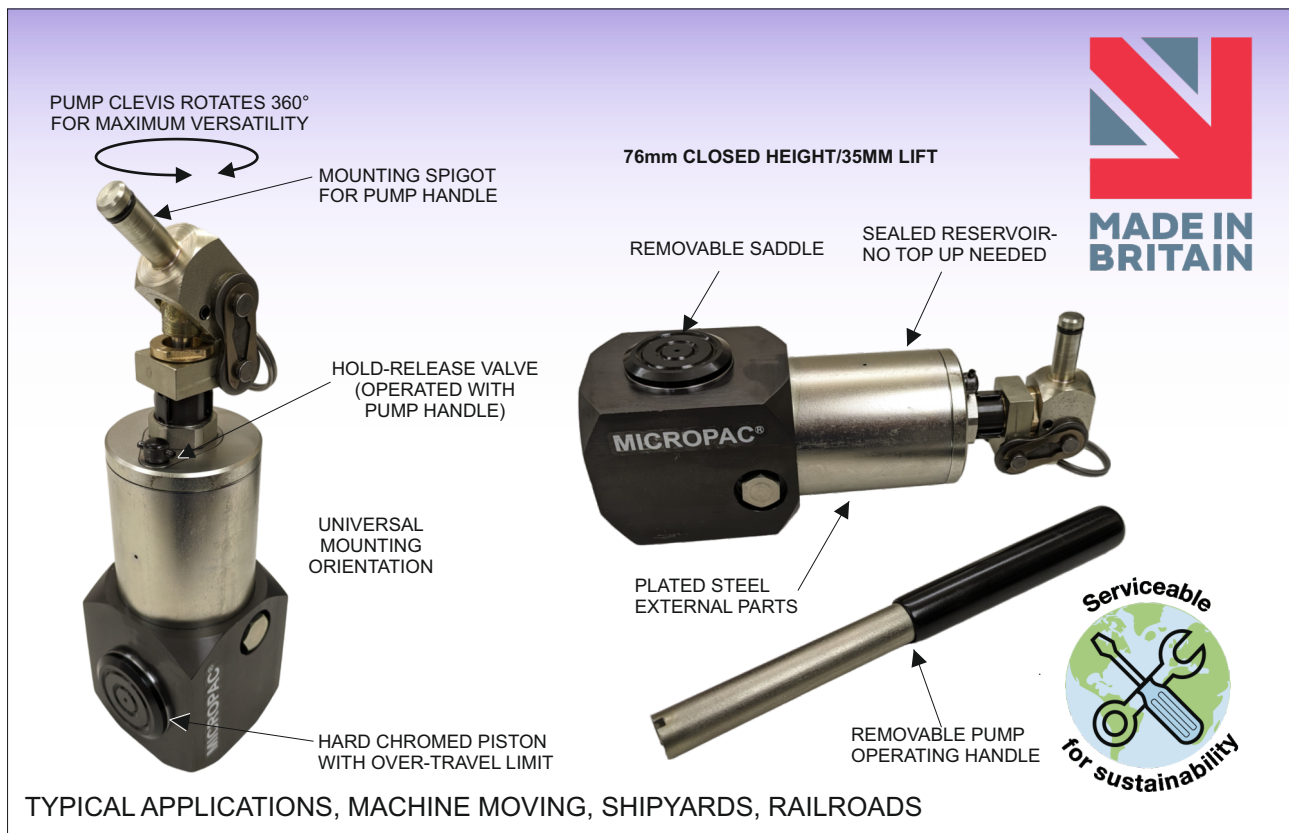

# Micropac® JAK series Compact 10 Tonne Hydraulic Jack



Quality engineered for the professional user

## FEATURES

- Lightweight and compact 10 tonne unit
- Small enough for your tool box
- 76mm Closed height, 35mm lift stroke
- Sealed reservoir; universal mounting orientation
- Sturdy construction with coated steel body
- Hard wearing piston with spring assisted return
- Reliable - British designed and manufactured
- Optional pressure gauge calibrated in tonnes
- User serviceable seals & seats
- Versatile; pump mechanism rotates through 360°
- Single acting operation - pumps on down stroke
- Load hold-release valve easily accessible
- Integral overload protection pressure relief valve
- Factory support for application and use

# INSTALLATION & MAINTENANCE

---

## APPLICATION

The JAK compact jack is ideally suited for applications requiring a lifting or positioning force in confined spaces.

It is lightweight, easy to operate and features a high grade steel body and hardened wear resistant piston for extended service life.

The piston has a detachable saddle and spring assisted return.

There is a load hold-release valve on the reservoir end; this is operated using the removable pump handle. The valve is unscrewed to release the load and retract the piston; it may be re-tightened at any point to hold the load again.

There is an internal safety overload pressure relief valve.

An optional pressure gauge is available, calibrated in tonnes.

The pumping mechanism rotates through 360° for maximum versatility. Pumping operation is single acting; pressure is applied on the down stroke.

The jack is supplied pre-filled with oil and the sealed hydraulic system allows it to be used in any orientation e.g sideways, upside down etc.

With a removable operating handle measuring only 205mm long, the jack will readily fit into a toolbox.

The jack is suitable for use in a dry environment.

## SAFETY

A risk assessment covering safe installation, operation and maintenance should always be carried out prior to use.

The unit satisfies the essential health & safety requirements of both the Machinery Directive 2006/42/EC and the UK Supply of Machinery (Safety) Regulations 2008.

The jack is designed to meet the requirements of BS EN 1494:2000 'Mobile or movable jacks and associated lifting equipment'.

The jack is CE and UKCA marked.

Article 4 paragraph 3 of the Pressure Equipment Directive (PED) 2014/68/EU applies; the equipment is manufactured under sound engineering practice and therefore meets the requirements of both the PED 2014/68/EU and the UK Pressure Equipment Regulations 2016.

## INSTALLATION

The jack is factory supplied pre-filled with hydraulic oil and ready for use. Mount the unit on a flat surface with lifting load perpendicular and central to saddle.

**The load must not be offset or to one side of the piston.**

## WARNINGS

**ALWAYS** raise the piston to the load

**DO NOT** drop load onto jack

**ALWAYS** support the base of the jack when in use

**NEVER** go under load when only the jack supports it

**DO NOT** attempt to lift load greater than 10 tonnes

**ALWAYS** provide solid and flat foundations for the jack

**ALWAYS** ensure sufficient spare lifting capacity and stroke

**ALWAYS** check jack load rating before use

**ALWAYS** avoid off-centre loading

## OPERATION

### To lift or push a load

Engage the slotted pump operating handle with the head of the load hold-release on the end of the jack reservoir. Rotate clockwise to close the valve; do not over-tighten.

Refit the operating handle onto the pump clevis and rotate the handle to achieve a comfortable pumping position. Move handle downwards to operate pump (there is no pump action on the up stroke). The piston will move out to meet and lift the load. Continue pumping until desired position is reached. Observe pressure gauge for load applied (where fitted). When the piston reaches full stroke, it will not move out any further.

Never exceed maximum rated load of 10 tonnes; there is an inbuilt overload pressure relief valve for protection of the jack.

### To lower load

Wherever possible and safe to do so, wipe the piston clean before lowering. Engage the slotted operating handle with the head of the hold-release valve. Rotate anticlockwise to open the valve; cracking the valve open will control rate of lowering. Do not overload the jack during lowering; the piston is spring retracted and will return of its own accord.

### After use

Store in a dry environment with the piston fully retracted.

## MAINTENANCE

**Maintenance operations should only be carried out by a competent service engineer.**

Service kits are available comprising all seals, seats, balls and springs.

The hydraulic system is sealed and does not need any topping up.

Sarum Hydraulics Ltd also offer a servicing facility; please advise before returning the unit to us.

# SPECIFICATION

---

Maximum load: 10 tonnes

Safety overload pressure relief valve: set at 10 tonnes

Relief valve may be factory set at a different load; please specify at time of ordering

Maximum stroke length: 35mm, Closed height 76mm

Single acting operation, pump displacement on down stroke

Displacement per pump stroke: 0.5cc

Nom. operating hand load (at 10 tonnes): 308N

Ambient operating temperature range: -30 to 120°C

Weight: 4.5kg (inc. operating handle)

Materials of construction:

Body, reservoir- zinc plated carbon steel

Piston- hard chrome plated stainless steel

Pump mechanism, pump operating handle- zinc plated carbon steel

Hydraulic seals- nitrile elastomer, PTFE

Optional 63mm diameter pressure gauge, calibrated in tonnes.

Optional 'Minimess' quick release connection for pressure gauge Please stipulate pressure gauge requirements at time of ordering

# DIMENSIONS

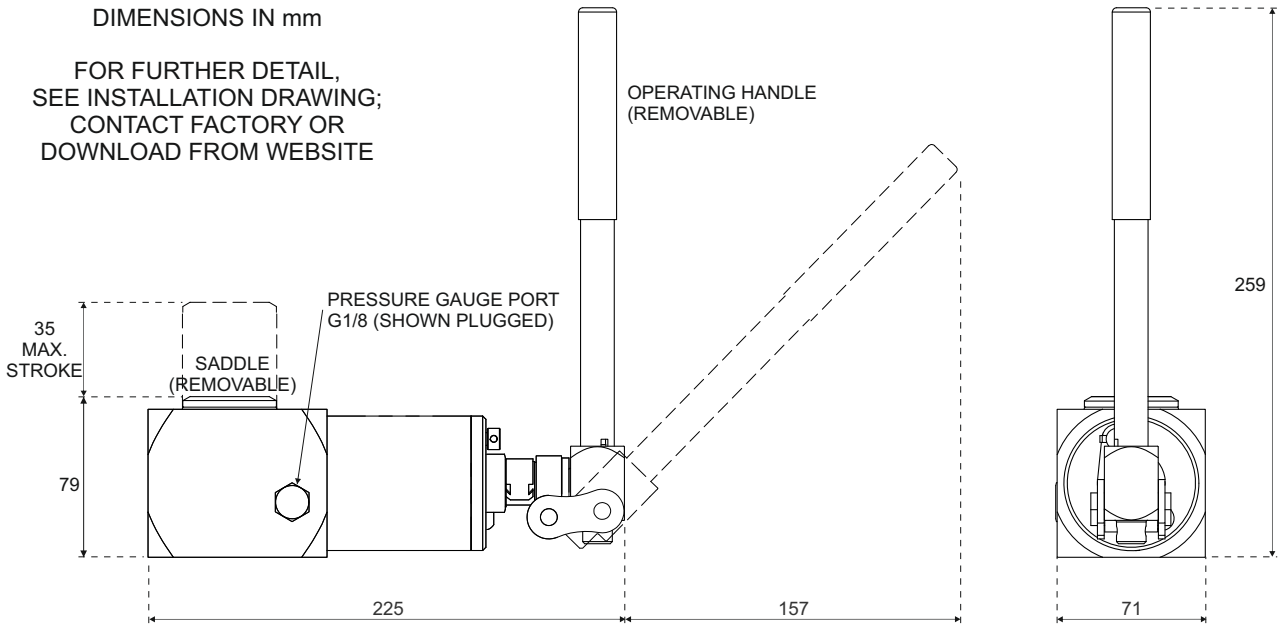
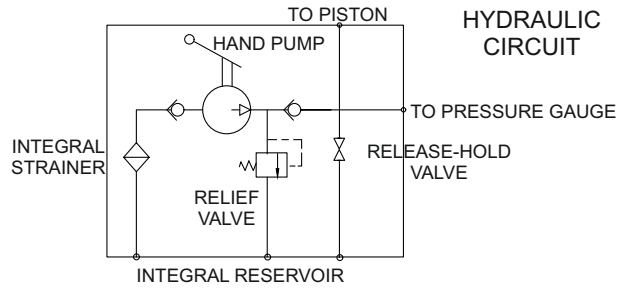
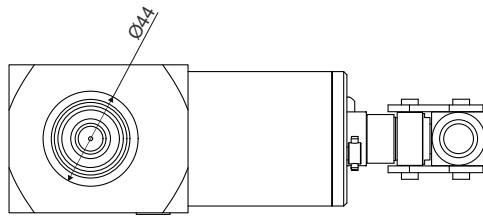

# ORDERING CODES

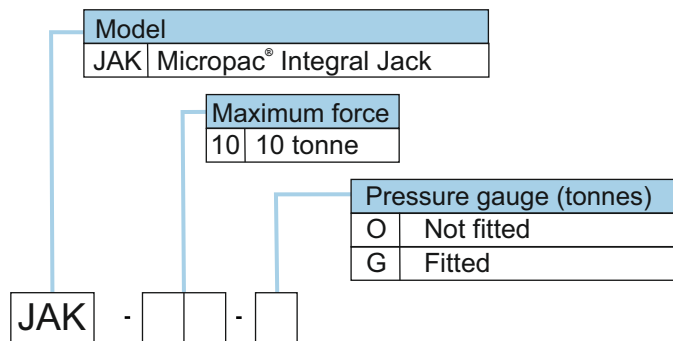

We are a long established ISO 9001:2015 certificated designer and manufacturer of hydraulic equipment. Full details of other products in our range are available from:

**Sarum Hydraulics Limited**  
 Unit 1 Danebury Court, Salisbury, SP4 6EB, UK  
 Tel: 44(0)1722 328388 Fax: 44(0)1722 414307  
 email: pumpsales@sarum-hydraulics.co.uk  
 www.sarum-hydraulics.co.uk



**SARUM**  
 HYDRAULICS  
 Designers & Manufacturers of Micropac® Hydraulics

We invest heavily and continuously in product development. Specifications are therefore liable to change without prior notification.  
 ®Micropac is a Registered Trade Mark of Sarum Hydraulics. E&OE.