

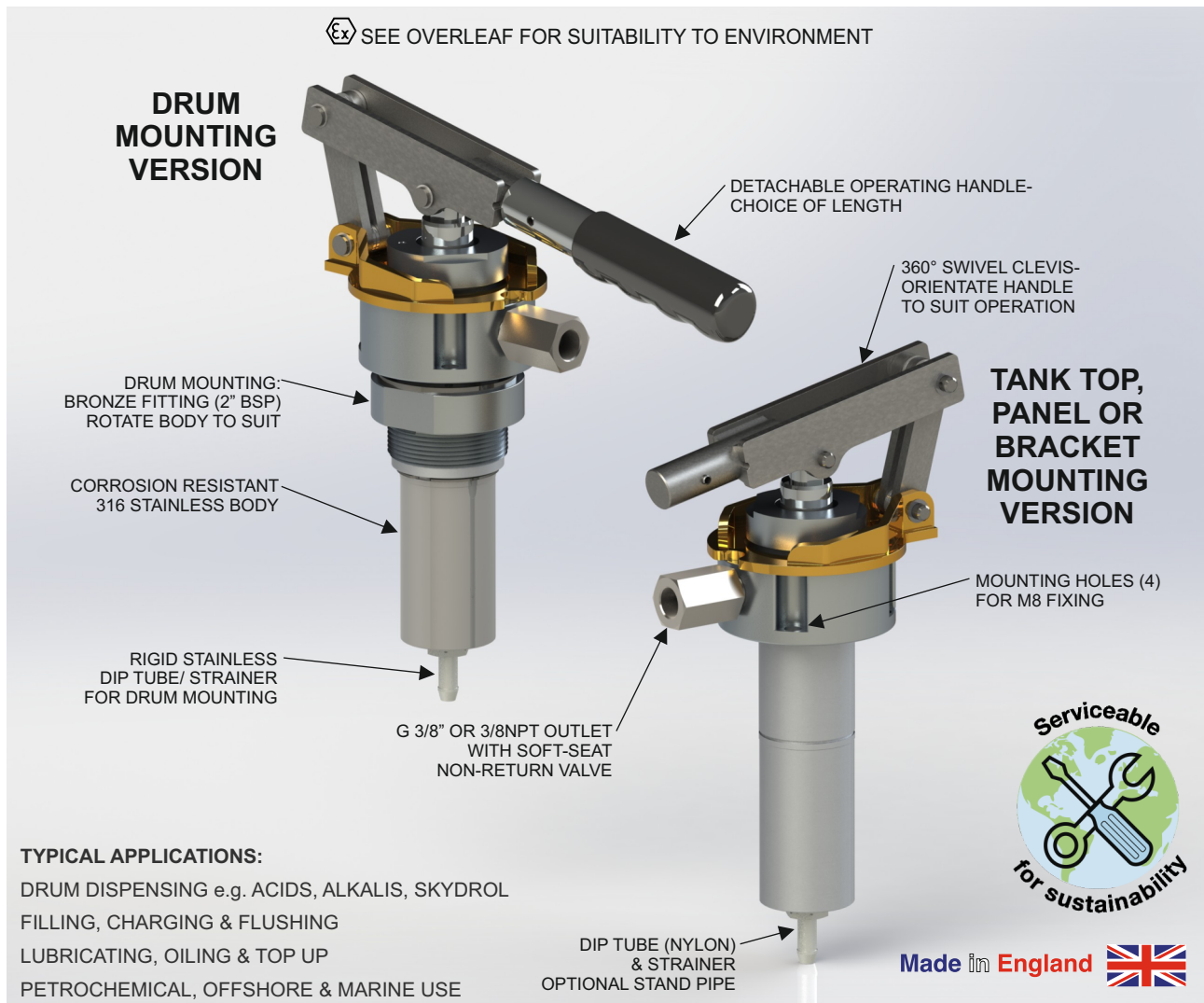

Micropac® Low Pressure Hand Pump for Potentially Explosive Atmospheres



UKEX, ATEX and IEC Ex certified FEATURES

- Cost effective dispensing and charging facility
- Rugged; suitable for extreme environments
- Drum, tank top or bracket mounting options
- Handle swivels 360° to suit operating position
- Durable; 316 stainless steel/ bronze construction
- Double acting; pumps on up and down stroke
- Delivers upto 3 litres/min. to max. pressure 25 bar
- Compatible with water, oil and other liquids
- Long life hard chromed stainless piston rod
- Dirt excluder and PTFE low friction sealing
- Nitrile seals standard - optional EPDM/ Viton®
- Choice of detachable operating handle length
- Soft-seat check valve for positive sealing
- Reliable- British design & manufacture
- User serviceable sealing & seating components
- Factory support for product and application

SUITABILITY FOR THE OPERATING ENVIRONMENT

Atmosphere

All equipment intended for use in potentially explosive atmospheres is marked in accordance with the requirements of the Equipment and Protective Systems Intended for use in Potentially Explosive Atmospheres Regulations 2016, the ATEX Directive 2014/34/EU, and BS EN ISO 80079-36:2016 .

The product nameplate shows

- the manufacturer (Sarum Hydraulics Ltd.)
- the product type identification
- the UKCA marking, denoting conformity with the Equipment and Protective Systems Intended for use in Potentially Explosive Atmospheres Regulations 2016
- the CE marking, denoting conformity with all the essential requirements of the ATEX Directive 2014/34/EU
- marking as detailed below, denoting the compatibility of the equipment within the operating environment, firstly as defined by the Equipment and Protective Systems Intended for use in Potentially Explosive Atmospheres Regulations 2016 and the ATEX Directive 2014/34/EU and then as defined by the requirements of BS EN ISO 80079-36:2016
- serial number
- certificate issuer and reference in the defined form

UK
CA

CE

Ex

II 2 G Ex h IIC T6 Gb

Ex

II 2 D Ex h IIIC T85°C Db

According to the Equipment and Protective Systems Intended for use in Potentially Explosive Atmospheres Regulations 2016 and the ATEX Directive 2014/34/EU, the marking denotes that the equipment is non-electrical intended to be used in Surface Industry classified as both Gas Explosive Atmosphere - Zone 1 and Explosive Atmosphere of Combustible Dust - Zone 21.

According to BS EN ISO 80079-36:2016, the marking denotes that the equipment is non-electrical conforming to this standard both for EPL Gb for use in explosive gas atmospheres of Group IIC and ignition temperature greater than 85 °C, and for EPL Db for explosive dust atmospheres containing dusts of Group IIIC and maximum surface temperature less than 85 °C.

Media

Subject to suitability of materials of construction, the unit is compatible for operation with group 1 liquids up to 500 bar and group 2 liquids up to 1000 bar according to the classification of liquids under the Pressure Equipment Directive 2014/68/EU, which cross refers to the Classification, Labelling and Packaging (CLP) Directive 1272/2008. These may be summarised as follows, but the text of the Directive Article 13 paragraph 1 fully defines those substances categorised as groups 1 and 2.

Group 1: explosive, extremely flammable, highly flammable, flammable (where the maximum allowable temperature is above flashpoint), toxic, serious health hazards, oxidising

Group 2: all other liquids

Elastomer sealing options are nitrile, fluorocarbon and ethylene propylene, specified at the time of ordering.

Please consult with the factory if in doubt.

Certification

This equipment is supplied with a Declaration of Conformity in accordance with the requirements of either the Equipment and Protective Systems Intended for use in Potentially Explosive Atmospheres Regulations 2016, or the ATEX Directive 2014/34/EU, or BS EN ISO 80079-36:2016. Any modification to the equipment by a third party may invalidate the certification.

INSTALLATION & MAINTENANCE

APPLICATION

This equipment is suitable for use in explosive atmospheres; check carefully product marking and assess whether the equipment can be used safely in the intended area under the expected operating conditions.

The hydraulic hand pump is intended for dispensing applications and low pressure applications (up to 25 bar). There is a soft seal outlet non-return valve for positive sealing and pressure holding in the external system. Note; there is no manual pressure hold/ release valve and therefore no means of fluid return to the reservoir back through the pump; should this be required, it would need to be built into the system externally.

Models are available for direct drum mounting into a G2 (2" BSPP) filler, for remote mounting supplied with a right angled bracket for mounting onto an adjacent surface, or for remote mounting into a reservoir or panel.

The pump is supplied with a rigid inlet dip tube and strainer; length is cut to suit. Remote mounting models: connection may also be made to the inlet standpipe connector.

Sealing options are nitrile, fluorocarbon and ethylene propylene elastomers, specified at time of ordering.

The operating handle is detachable and measures 150mm, 450mm or 625mm (where ordered).

Outlet connection (female) is G3/8 (3/8"BSPP) or 3/8"NPT, depending on ordering code.

Maximum suction head is 1 metre.

MATERIALS

The materials of construction are 316 stainless steel and polymer. Seals are PTFE, UHMWP and elastomer.

The barrel swivel and drum plug (where supplied) are aluminium bronze.

SAFETY

Refer to page 2 'Product Marking' and assess whether the equipment can be used safely in the intended area under the expected operating conditions.

If used in an application other than dispensing at pressures >1 bar, this unit is classified as a component forming part of a hydraulic pressure system. If forming part of a permanent installation, the system should be designed, operated and maintained in accordance with statutory requirements and other relevant instructions. A risk assessment covering safe installation, operation and maintenance should always be carried out prior to use. This product is classified under 'Sound Engineering Practice' of the Pressure Equipment Directive (PED) 2014/68/EU. As such, the applied CE marking does not relate to this Directive.

INSTALLATION- 2" BSP SCREW DRUM MOUNTING

Cut the pump dip tube/ filter (avoid swarf ingress) so that when the pump is installed in the reservoir, the filter end is just clear of the drum base. Connect the tube to the standpipe fitting on the pump inlet using the compression fitting supplied; ensure olives are leaktight- the pump will not operate if there is an air leak. Lower the pump unit into the drum filler and screw the bronze plug fully into the thread. Handle orientation is not important as the swivel design allows 360° rotation.

INSTALLATION- RESERVOIR OR REMOTE MOUNTING

Refer to 'Dimensions' for cutout detail clearance for barrel and four mounting holes. The pump mounts using four M8 x 25 long socket head cap screws. Alternatively, the pump may be mounted using the right angled bracket (where specified) and suitable fixings (not supplied); bracket mounting hole details as shown in 'Dimensions'.

Reservoir mounting: cut 12mm dia. inlet tube to go between the two couplings supplied, avoiding any swarf ingress to tube end, length such that inlet strainer is just clear of reservoir base with pump in position. Fully tighten coupling nuts to ensure no air ingress. **Remote mounting;** connect inlet tube using suitable coupling; a bore of 9mm dia. minimum must be maintained and the media must be clean and free from particulates.

Position the pump and align with mounting holes. Using the socket head cap screws supplied, tighten evenly to 15Nm. Do not use any joining compound. Follow the same procedure if mounting onto the bracket; M8 nuts & washers are required on underside of bracket.

OUTLET CONNECTION

The outlet connection is G3/8 or 3/8NPT female. Make connection to outlet hose or pipework using suitable adaptor.

COMMISSIONING

Fit operating handle to handle spigot. Ensure that fluid reservoir is filled. Make connection of delivery hose or pipework to external system, as applicable. Operate the handle by moving up and down until maximum required pressure is achieved. The pump operates on both the up and down strokes. Check for leaks in the system. Release pressure as applicable to system.

MAINTENANCE

Maintenance operations should only be carried out by a competent service engineer.

The inlet and outlet check valves are serviceable and employ replaceable seats. Service kits are available comprising all seals, seats, balls and springs.

The pump inlet strainer should be checked periodically for fouling. To do this, the pump should be removed from the reservoir; ensure that the mounting gasket is in good condition when refitting, and that the pump mounting screws are sufficiently tightened to effect a seal between the pump and reservoir.

Sarum Hydraulics Ltd also offer a servicing facility; please advise before returning the unit to us.

SPECIFICATION

Displacement per double stroke/ max. pressure
100cc up to 25 bar

Max. handle load at 25 bar: approx. 220N (450mm handle)

Max. flow: typically 3 litres/minute @ 30 strokes/minute

Maximum suction head: 1 metre

Compatibility: water, water-glycol, mineral oil (nitrile seals).

Fluorocarbon and EPDM sealing options- check

compatibility first; if in doubt, consult factory.

Ambient operating temperature range: -20 to 40°C

Media operating temperature range:

Nitrile: -35 to 80°C

Fluorocarbon: -26 to 80°C

EPDM: -50 to 80°C

Weight: 5kg

DIMENSIONS

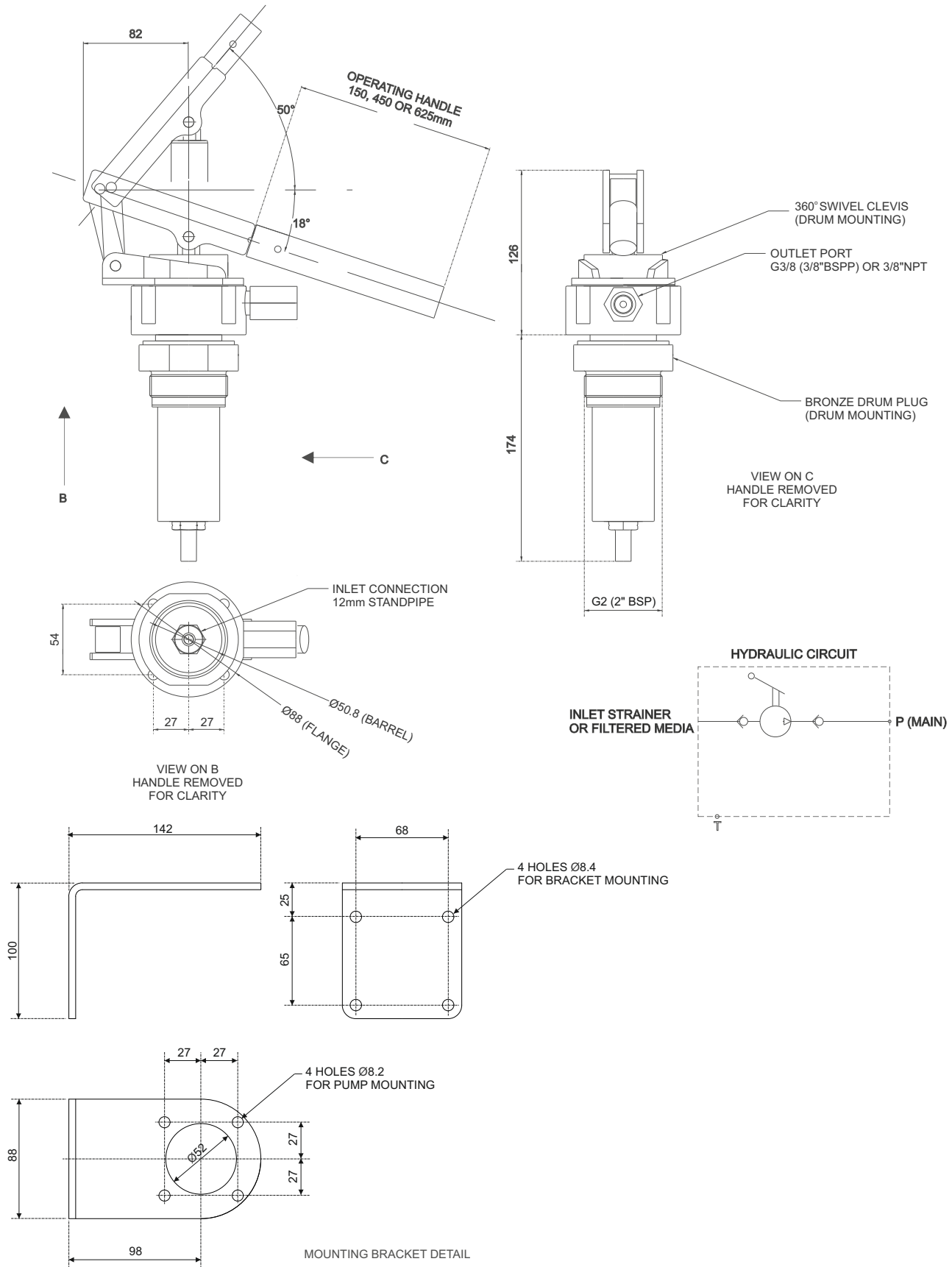

ORDERING CODES

Product is marked according to the following ordering code:

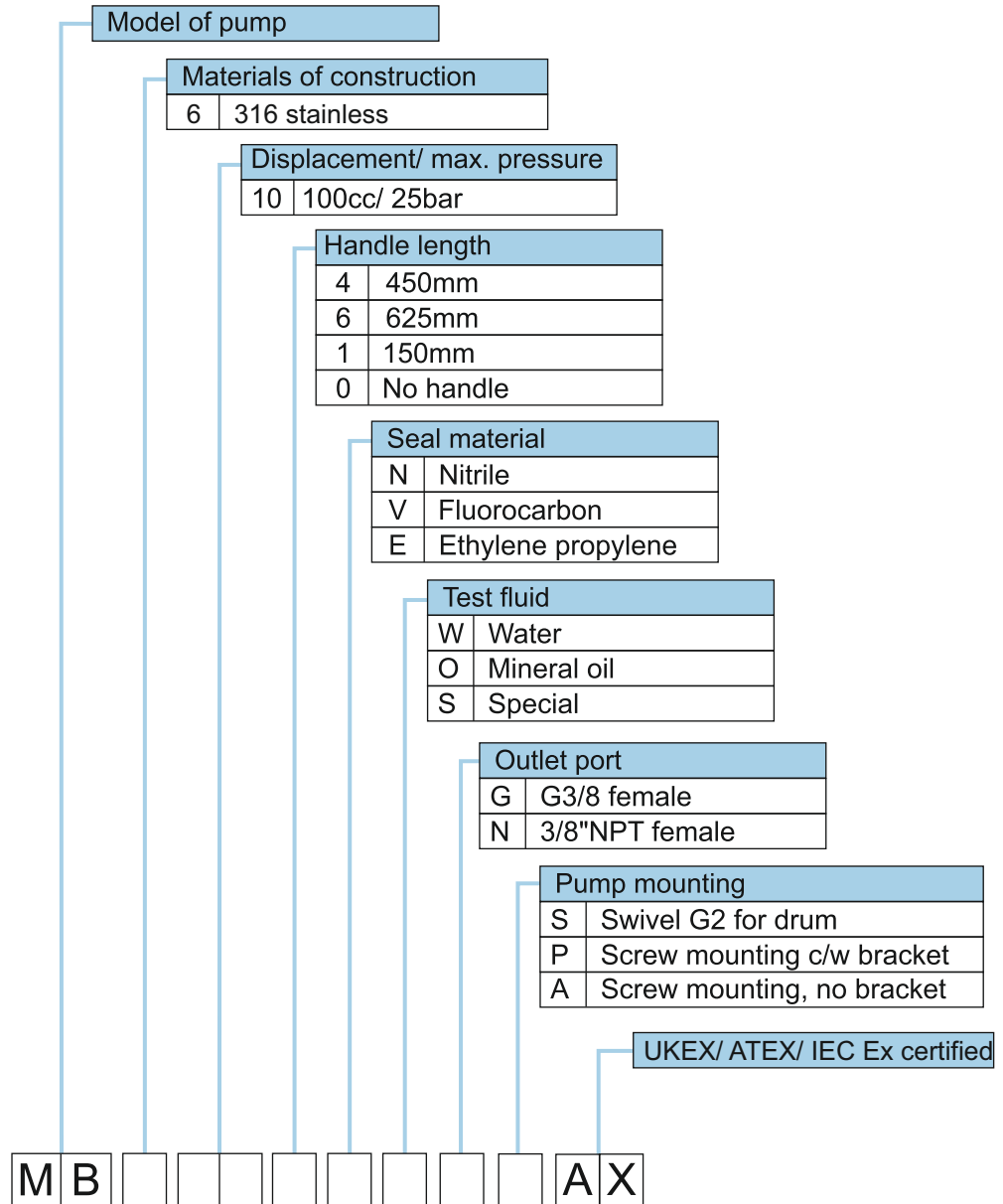

Sarum Hydraulics Ltd are an ISO 9001:2015 certified company with over 35 years experience in design and manufacture of hydraulic equipment. Call us, email us or visit our website to find out more about our extensive product range. Enquiries are welcomed for bespoke solutions.

Sarum Hydraulics Limited
 Unit 1 Danebury Court, Salisbury, SP4 6EB, UK
 Tel: 44(0)1722 328388 Fax: 44(0)1722 414307
 email: pumpsales@sarum-hydraulics.co.uk
 www.sarum-hydraulics.co.uk



SARUM
 HYDRAULICS
 Designers & Manufacturers of Micropac® Hydraulics

We invest heavily and continuously in product development.
 Specifications are therefore liable to change without prior notification.
 ® Micropac is a Registered Trade Mark of Sarum Hydraulics. E&OE.