



Micropac® MT series C10-2 Cavity Cartridge Hydraulic Hand Pump

**Serviceable
for sustainability**

HIGH STRENGTH ALUMINIUM ALLOY CLEVIS WITH DETACHABLE CARBON STEEL OPERATING HANDLE ON MT-A UNITS (HANDLE NOT SHOWN)
HARD ANODISED ALLOY CLEVIS/SWIVEL ON MT-3

MT-3, MT-6 MODELS

316 STAINLESS CLEVIS/SWIVEL ON MT-6
HARD ANODISED ALLOY ON MT-3

HARD CHROMED PISTON ROD FOR EXTENDED SERVICE LIFE

CORROSION RESISTANT BRONZE BEARING (MT-6 MODEL)

303 STAINLESS BODY & BEARING (MT-3)
316 STAINLESS BODY (MT-6)

PUMP MOUNTS INTO C10-2 7/8"-14 UNF 2 PORT INDUSTRY STANDARD CAVITY TANK CONNECTION ON NOSE

MT-A MODEL

HANDLE MECHANISM FEATURES 360° SWIVEL ON PTFE BEARING-ORIENTATE HANDLE TO SUIT

PLATED STEEL BODY & BEARING

OPTIONAL MANIFOLD MOUNTING BLOCK IN ALLOY OR 316 STAINLESS

TYPICAL APPLICATION:
MANUAL BACK-UP FOR POWERED HYDRAULIC SYSTEMS

Made in England

A compact and cost effective solution for manual hydraulic power

FEATURES

- Direct mounting into industry standard cavity
- Cost effective- no interconnecting pipework
- Suitable for use with mineral oil (nitrile seals)
- Single acting operation on down stroke
- 'Swivel' handle- 360° rotation to suit operation
- Built in strainer on pump inlet for added reliability
- Sturdy construction with plated steel body
- Optional 303/316 stainless steel body
- 2 port manifold mounting block available
- Hard chromed piston rod for long life
- Models available to cover pressures 150-400 bar
- Fluid displacement per stroke 4.3-11cc
- Operating handle easily removable for storage
- Lightweight - from 0.75kg excluding handle
- Nitrile seals standard - optional EPDM / Viton®
- Operating temperature range -20°C to 80°C
- Tank connection on nose
- Inlet and outlet check valves built in

INSTALLATION & MAINTENANCE

APPLICATION

The unit is suitable for any application requiring manual generation of hydraulic power eg operating hydraulic cylinders or actuators, piloting valves, charging accumulators or hydrostatic testing. On the up stroke, fluid is drawn in through the strainer and inlet check valve on the body end; on the down stroke fluid is displaced out through body annulus to align with the cavity port. The outlet check valve maintains system pressure.

A detachable operating handle mounts into the clevis orifice

The pump is available in 4 displacement per stroke/ maximum pressure ranges; 4.3cc/ 400 bar, 5.6cc/250 bar, 8cc/ 200 bar, and 11cc/ 150 bar.

Sealing options are nitrile, fluorocarbon and ethylene propylene elastomers, specified at time of ordering. Other options; please enquire.

Universal mounting orientation e.g vertical, horizontal.

MATERIALS

The materials of construction are zinc plated carbon steel or 303 stainless steel body, aluminium alloy swivel and handle clevis, other parts in stainless steel, UHMWP, PTFE, Polyurethane and elastomeric sealing. Consult factory if in doubt.

Also available with 316 stainless steel body, aluminium bronze bearing and hard anodised aluminium alloy swivel and handle clevis.

SAFETY

This unit is a component forming part of a hydraulic pressure system. If forming part of a permanent installation, the system should be designed, operated and maintained in accordance with statutory requirements and other relevant instructions. A risk assessment covering safe installation, operation and maintenance should always be carried out prior to use.

Under the EU Pressure Equipment Directive (PED) 2014/68/EU and the UK Pressure Systems (Safety) Regulations, the unit is not required to be CE or UKCA marked.

INSTALLATION

Suitable for manifold mounting into an industry standard cavity type C10-2 (2 port, 7/8"-14UNF thread) with tank on nose, outlet to side port.

Ensure pump body seals are lubricated and required cleanliness is maintained. The pump body must be carefully inserted on the axis of the cavity and screwed into the cavity, ensuring the outlet check valve is not damaged or dislodged.

Recommended tightening torque when screwing pump body into cavity: 45-50 Nm.

CONNECTIONS

Through cavity. As with any hand pump, the inlet line back to tank should be kept as short and unconstricted as possible for optimum performance.

COMMISSIONING

Locate operating handle into clevis orifice and orientate to suit operator position.

The pump should be operated after installation to leak test and bleed the hydraulic circuit. Failure to do so may result in reduced pump displacement and a spongy action.

MAINTENANCE

Maintenance operations should only be carried out by a competent service engineer.

The inlet strainer is easily accessible for cleaning. The inlet and outlet check valves are also easily serviced. Seals are replaced using standard tools. Service kits are available. The external thread, seals and check valve components should all be protected from damage during storage or maintenance. Check that the outlet check valve has not been damaged or dislodged during maintenance.

Sarum Hydraulics Ltd also offer a servicing facility; please advise before returning the unit to us.

DIMENSIONS

DIMENSIONS IN mm

FOR FURTHER DETAIL, SEE INSTALLATION DRAWINGS
CONTACT FACTORY OR DOWNLOAD FROM WEBSITE

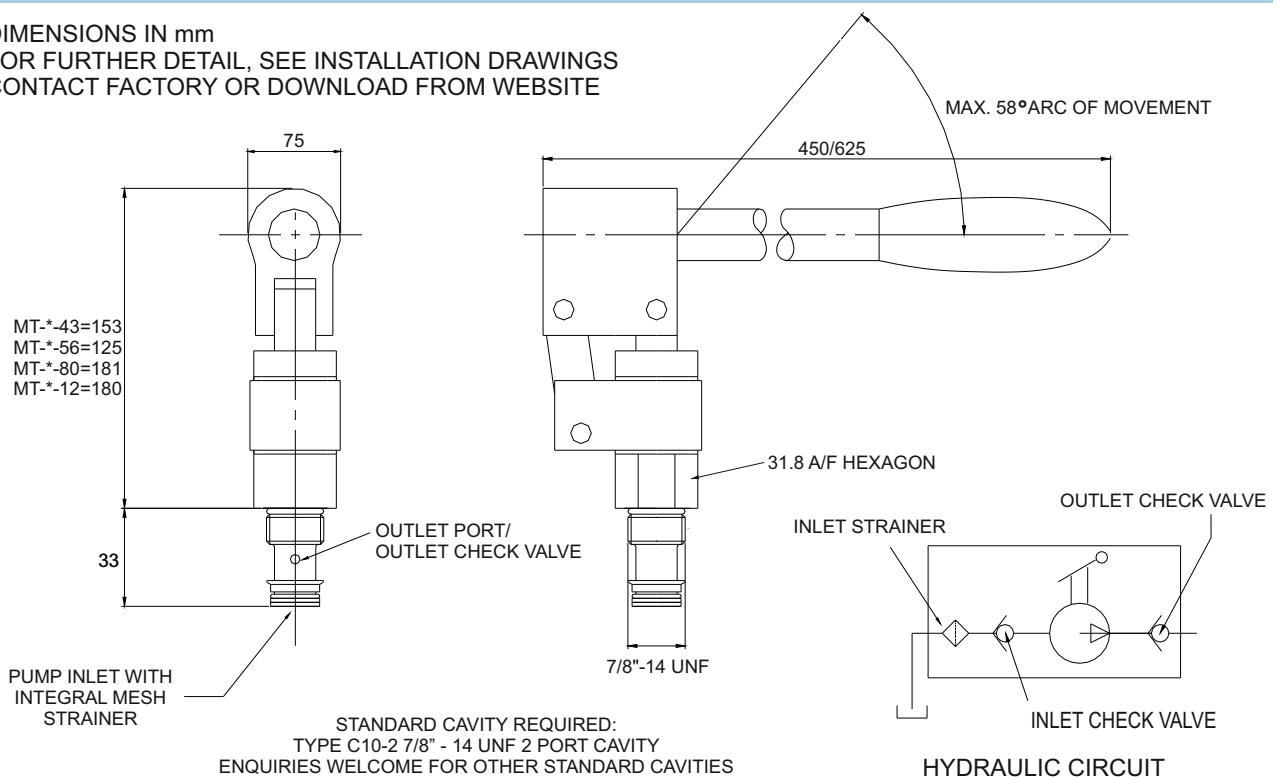

ORDERING CODES

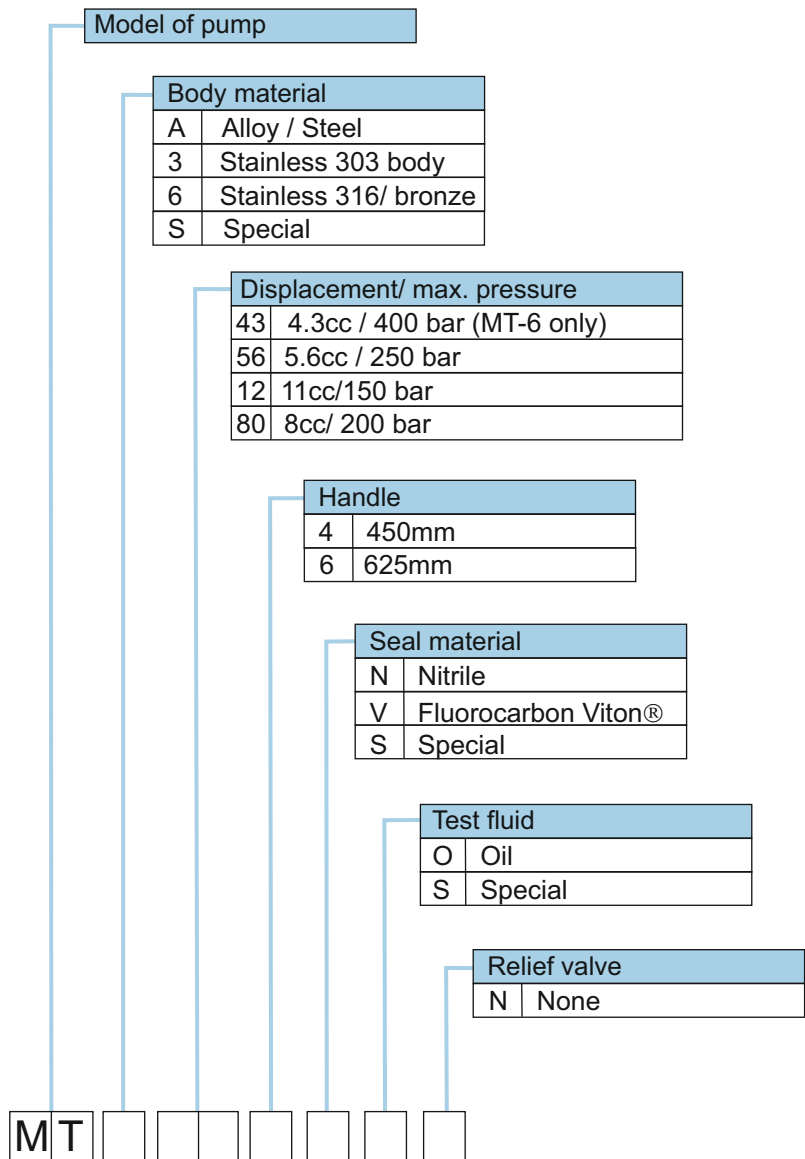

SPECIFICATION

Displacement/ stroke, max. operating pressure, max. flow:

MT*-43: 4.3cc, 400 bar, 0.17 lt/min

MT-3-56: 5.6cc, 250 bar, 0.22 lt/min

MT-3-80: 8cc, 200 bar, 0.32 lt/min

MT-3-12: 11cc, 150 bar, 0.44 lt/min

Nom. operating hand load (450mm, at max. pressure):

MT*-43, MT*-56: 402N

MT*-80, MT*-12: 476N

Compatibility: mineral oil (nitrile seals).

Fluorocarbon and EPDM sealing options- check compatibility first; if in doubt, consult factory.

Ambient operating temperature range: -20 to 40°C

Media operating temperature range:

Nitrile: -35 to 80°C

Flurocarbon: -26 to 80°C

EPDM: -50 to 80°C

We are a long established ISO 9001:2015 certificated designer and manufacturer of hydraulic equipment. Full details of other products in our range are available from:

Sarum Hydraulics Limited

Unit 1 Danebury Court, Salisbury, SP4 6EB, UK

Tel: 44(0)1722 328388 Fax: 44(0)1722 414307

email: pumpsales@sarum-hydraulics.co.uk

www.sarum-hydraulics.co.uk



SARUM
HYDRAULICS
Designers & Manufacturers of Micropac® Hydraulics

We invest heavily and continuously in product development.

Specifications are therefore liable to change without prior notification.

®Micropac is a Registered Trade Mark of Sarum Hydraulics. E&OE.