

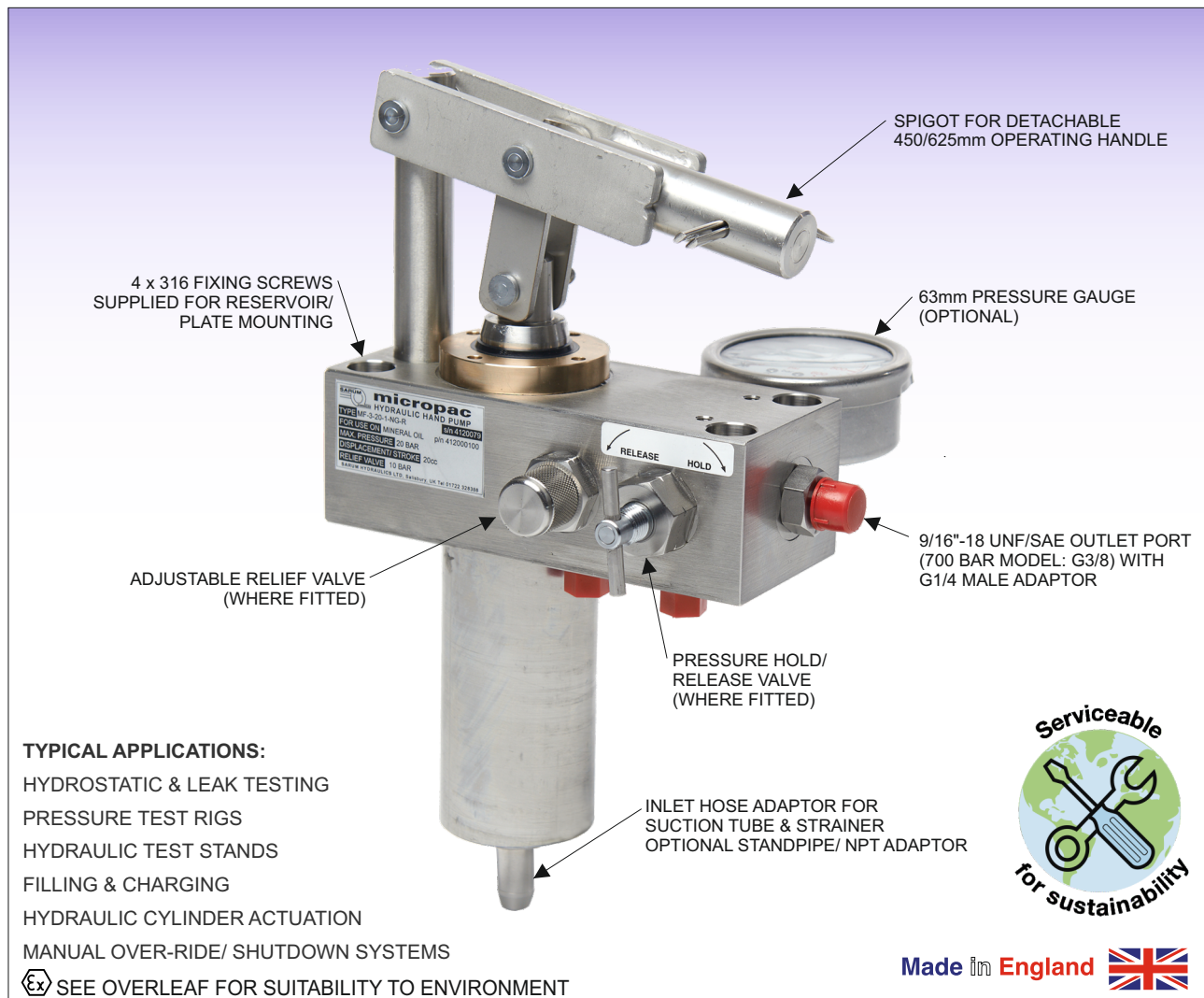

Micropac® Hydraulic Hand Pump for Potentially Explosive Atmospheres



UKEX, ATEX and IEC Ex certified FEATURES

- Double acting - pumps on up and down strokes
- 316 stainless steel/ bronze construction
- Five models cover max. pressures 50 - 700 bar
- Compatible with water, oil and other liquids
- Reliable- British design & manufacture
- Sturdy construction- for extreme environments
- Long life hard chromed stainless piston rod
- Dirt excluder and PTFE low friction sealing
- Soft-seat check valve for positive sealing
- Pressure gauge, release & relief valve options
- User serviceable sealing & seating components
- Detachable 450mm or 625mm operating handle
- Nitrile seals standard - optional EPDM/ Viton®
- Universal mounting orientation
- Optional range of 316 fixed mounting reservoirs
- Factory support for product and application

SUITABILITY FOR THE OPERATING ENVIRONMENT

Atmosphere

All equipment intended for use in potentially explosive atmospheres is marked in accordance with the requirements of the Equipment and Protective Systems Intended for use in Potentially Explosive Atmospheres Regulations 2016, the ATEX Directive 2014/34/EU, and BS EN ISO 80079-36:2016 .

The product nameplate shows

- the manufacturer (Sarum Hydraulics Ltd.)
- the product type identification
- the UKCA marking, denoting conformity with the Equipment and Protective Systems Intended for use in Potentially Explosive Atmospheres Regulations 2016
- the CE marking, denoting conformity with all the essential requirements of the ATEX Directive 2014/34/EU
- marking as detailed below, denoting the compatibility of the equipment within the operating environment, firstly as defined by the Equipment and Protective Systems Intended for use in Potentially Explosive Atmospheres Regulations 2016 and the ATEX Directive 2014/34/EU and then as defined by the requirements of BS EN ISO 80079-36:2016
- serial number
- certificate issuer and reference in the defined form

UK
CA

CE

Ex

II 2 G Ex h IIC T6 Gb

Ex

II 2 D Ex h IIIC T85°C Db

According to the Equipment and Protective Systems Intended for use in Potentially Explosive Atmospheres Regulations 2016 and the ATEX Directive 2014/34/EU, the marking denotes that the equipment is non-electrical intended to be used in Surface Industry classified as both Gas Explosive Atmosphere - Zone 1 and Explosive Atmosphere of Combustible Dust - Zone 21.

According to BS EN ISO 80079-36:2016, the marking denotes that the equipment is non-electrical conforming to this standard both for EPL Gb for use in explosive gas atmospheres of Group IIC and ignition temperature greater than 85 °C, and for EPL Db for explosive dust atmospheres containing dusts of Group IIIC and maximum surface temperature less than 85 °C.

Media

Subject to suitability of materials of construction, the unit is compatible for operation with group 1 liquids up to 500 bar and group 2 liquids up to 1000 bar according to the classification of liquids under the Pressure Equipment Directive 2014/68/EU, which cross refers to the Classification, Labelling and Packaging (CLP) Directive 1272/2008. These may be summarised as follows, but the text of the Directive Article 13 paragraph 1 fully defines those substances categorised as groups 1 and 2.

Group 1: explosive, extremely flammable, highly flammable, flammable (where the maximum allowable temperature is above flashpoint), toxic, serious health hazards, oxidising

Group 2: all other liquids

Elastomer sealing options are nitrile, fluorocarbon and ethylene propylene, specified at the time of ordering.

Please consult with the factory if in doubt.

Certification

This equipment is supplied with a Declaration of Conformity in accordance with the requirements of either the Equipment and Protective Systems Intended for use in Potentially Explosive Atmospheres Regulations 2016, or the ATEX Directive 2014/34/EU, or BS EN ISO 80079-36:2016. Any modification to the equipment by a third party may invalidate the certification.

INSTALLATION & MAINTENANCE

APPLICATION

Please refer to page 2 when determining suitability for operation in a potentially explosive atmosphere.

This equipment is suitable for use in both indoor and outdoor applications; the 316 stainless steel construction makes it ideal for saline environments. A range of stainless steel reservoirs is also available.

The hydraulic hand pump provides manual hydraulic power for a range of applications such as manual back up systems and hydrostatic testing. It is fitted with a soft seat outlet check valve and is thus ideal for leak testing. Pumping operation is double acting; fluid is displaced on both the up and down strokes.

The pump is available in 5 displacement per double stroke/ maximum pressure ranges; 7cc/ 700 bar, 12cc/400 bar, 25cc/ 200 bar, 49cc/ 100 bar, and 100cc/ 50 bar.

Please refer to page 2 for compatibility with group 1 and group 2 liquids, and check materials of construction are compatible with the operating media. Sealing options are nitrile, fluorocarbon and ethylene propylene elastomers, specified at time of ordering.

Depending on specification, the pump may be fitted with a soft seat pressure hold/ release needle valve, an adjustable pressure relief valve, and a pressure gauge.

The 316 polished stainless steel operating handle is detachable and measures 450mm or 625mm.

The pump is intended for direct mounting onto a suitable reservoir, but can also be remote mounted and piped into a system- contact factory for connection options.

MATERIALS

The materials of construction are 316 stainless steel, aluminium bronze, UHMWP, PTFE and elastomeric sealing.

SAFETY

This unit is a component forming part of a hydraulic pressure system. If forming part of a permanent installation, the system should be designed, operated and maintained in accordance with statutory requirements and other relevant instructions. A risk assessment covering safe installation, operation and maintenance should always be carried out prior to use.

INSTALLATION

The pump can be mounted vertically or horizontally; the pump inlet has to be fully immersed in the pumped media at all times.

Reservoir mounting: refer to pump dimensions section for mounting interface detail. The reservoir top plate requires cut outs for the pump barrel, relief and release drain ports and four M8 tapped holes for pump mounting. The reservoir should be vented to atmosphere. Cut the pump dip tube and filter assembly so that the filter end touches the reservoir base. The inlet hose connector is designed to accept 9.5mm i.d. nylon tube (12mm i.d. on 100cc units). Push the tube onto the barbed pump inlet. Locate the mounting gasket supplied with the pump onto the reservoir top plate such that the release/relief valve drain holes align. No jointing compound should be

INSTALLATION continued

used. Lower the pump into position and secure using the four M8 x 65 long socket head cap screws supplied, tighten evenly to a torque of 15Nm.

Before mounting the reservoir, consider ergonomics of pump handle operation; refer to pump dimensions section. Mount the reservoir on a surface that can withstand handle forces during pumping to maximum required pressure. Use the mounting holes provided; fixings are not supplied.

Remote mounting: mounting detail as for reservoir. Make connection to inlet using suitable coupling, ensuring media is filtered.

CONNECTIONS

The outlet connection is a 9/16" UNF SAE female port (G3/8 on 7cc/ 700 bar unit); a G1/4 male 60° coned adaptor is fitted as standard. Make connection to system using suitable swivel nut & nipple, or female adaptor fitting.

The pressure gauge port is G1/4 flat bottomed and is plugged where a pressure gauge is not supplied.

COMMISSIONING

The reservoir may be filled by unscrewing the filler cap and topping up to desired level with clean fluid; do not over fill. Where fitted, use the dipstick to determine fluid level. Always refit filler cap after top up.

Fit operating handle to handle spigot. If fitted, close the soft seat release/ hold valve by screwing knob in fully clockwise; do not overtighten. Operate the handle by moving up and down until maximum required pressure is achieved. Check for leaks in the system.

To release pressure, unscrew release/ hold valve knob, slowly for a controlled release.

To set relief valve, remove cap, adjust set screw whilst operating hand pump to achieve maximum pressure requirement, then refit cap.

MAINTENANCE

Maintenance operations should only be carried out by a competent service engineer.

The inlet and outlet check valves are serviceable and employ replaceable seats. Service kits are available comprising all seals, seats, balls and springs.

The pump inlet strainer should be checked periodically for fouling. To do this, the pump should be removed from the reservoir; ensure that the mounting gasket is in good condition when refitting, and that the pump mounting screws are sufficiently tightened to effect a seal between the pump and reservoir.

The reservoir media should be kept clean.

If using aqueous media, ensure that the reservoir is protected from low temperatures to prevent against risk of freezing.

Sarum Hydraulics Ltd also offer a servicing facility; please advise before returning the unit to us.



**PROTECTING THE ENVIRONMENT
DESIGNED FOR LIFE**

DIMENSIONS

ALL DIMENSIONS IN mm

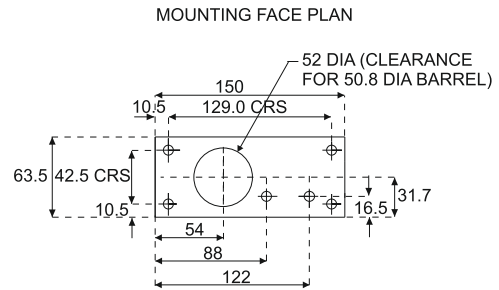
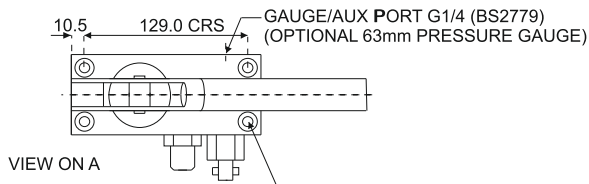

MOUNTING HOLES 8 THRO' FOR M8 SCREWS (SUPPLIED)
RECOMMENDED TIGHTENING TORQUE: 15Nm

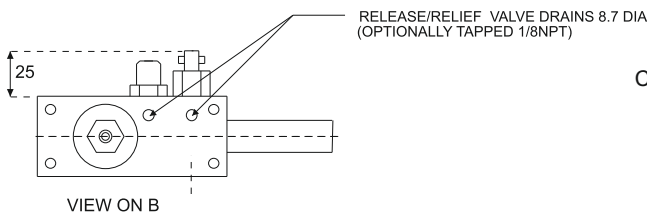
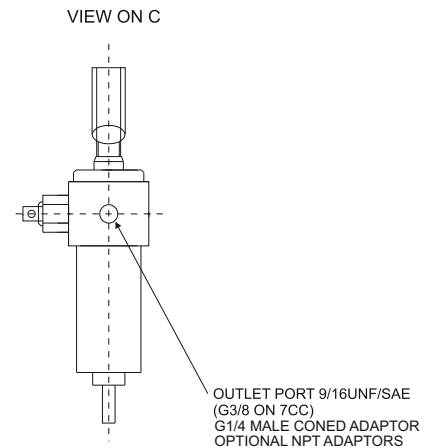
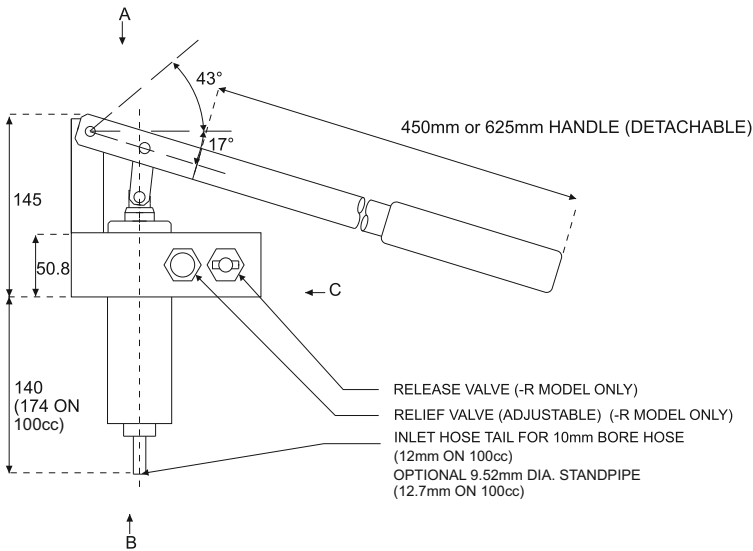

CIRCUIT DIAGRAM- RELEASE AND RELIEF VALVES SHOWN

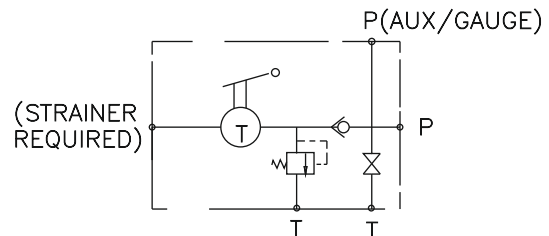

INSTALLATION DRAWING 007000200 AVAILABLE UPON REQUEST

SPECIFICATION

Displacement/ double stroke, max. operating pressure:

- MW-3-7: 7cc, 700 bar
- MW-3-12: 12cc, 400 bar
- MW-3-25: 25cc, 200 bar
- MW-3-49: 49cc, 102 bar
- MW-3-100: 100cc, 50 bar

Max. flow (typical):

- 100cc/stroke = 4 litres/ minute
- 50cc/ stroke = 2 litres/ minute
- 25cc/ stroke = 1 litre/ minute
- 12cc/ stroke = 0.5 litres/ minute
- 7cc/ stroke = 0.3 litres/ minute

Nom. operating hand load (625mm, max. pressure): 460N

Compatibility: group 1 and group 2 liquids- see page 2 for full details. Typical applications; water, water-glycol, mineral oil (nitrile seals). Fluorocarbon and EPDM sealing options-check compatibility first; if in doubt, consult factory.

Ambient operating temperature range: -20 to 40°C

Media operating temperature range:

- Nitrile: -35 to 80°C
- Flurocarbon: -26 to 80°C
- EPDM: -50 to 80°C

Weight: 7kg

For **reservoir specifications**, please refer to our MR reservoir datasheet ref. 001026300.

