

IF IN DOUBT, ASK THIRD ANGLE PROJECTION

NOTES

1. MATERIALS OF CONSTRUCTION
316 STAINLESS 1.4404
POLYMER CAP/FILLER MESH
POLYPROPYLENE/RUBBER WHEELS
PVC HANDLE GRIPS
2. ALL DIMENSIONS IN mm
3. MASS 44 KG
4. USE DATA SHEET 485004800 FOR "MY" SERIES FOUR-WHEEL TURNTABLE TROLLIES
5. MAX LOAD CAPACITY 500KG
6. HAND MANEUVERED ONLY, NOT SUITABLE FOR TOWING

TOLERANCES UNLESS OTHERWISE STATED
 GENERAL TOLERANCES RIGHT ANGLE BENDS &
 NO DEC. PLACE +/-1.0mm OTHER ANGLES +/-1°
 ONE DEC. PLACE +/-0.3mm MACHINED DIAMETERS
 TWO DEC. PLACE +/-0.1mm CONCENTRIC WITHIN
 +/-0.1mm T.I.R.
 SCREW THREADS ARE ISO METRIC COARSE PITCH
 TOL. 6g/6h (MED. FIT) TO BS3643
 WIRE DIA./PLATE THICKNESS TO COMMERCIAL LIMITS
 GEOMETRICAL TOLERANCING TO BS308 PART 3

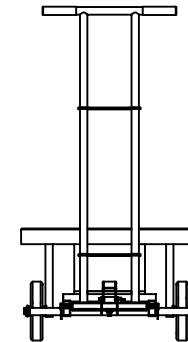
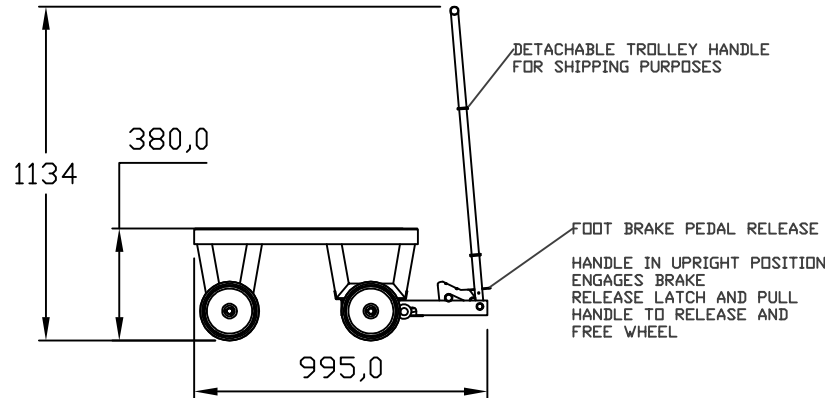
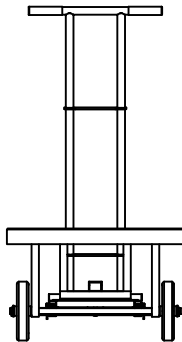
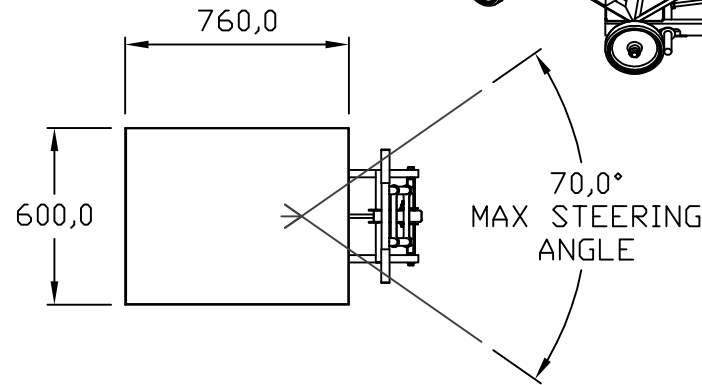
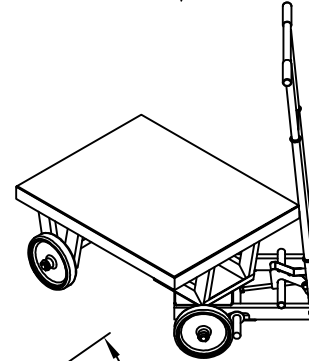
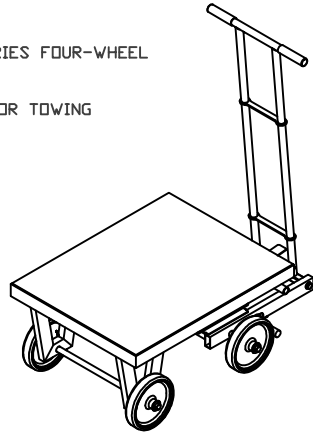

UNLESS OTHERWISE STATED:
 DIMENSIONS IN MILLIMETRES
 SURFACE FINISH IN MICROMETRES
 REMOVE SHARP EDGES

© COPYRIGHT 2023 SARUM HYDRAULICS LTD.



SARUM HYDRAULICS LTD.

SALISBURY, SP4 6EB, UK
 www.sarum-hydraulics.co.uk

TITLE
INSTALLATION DRAWING TURNTABLE TROLLEY 760DECK

DRAWN N.0 APP

CHKD

SCALE F SIZE SHEET OF

CAD 2-D MY-0806-316-PR

DRAWING NO.

MY-0806-316-PR

1	FIRST ISSUE	10/23
ISSUE	D.C.N.	CHANGE DESCRIPTION & DATE
		DATE IMPLEMENTED

MATERIAL PER NOTE
FINISH PER NOTE

IF IN DOUBT, ASK THIRD ANGLE PROJECTION

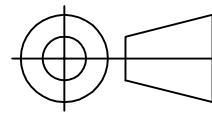

TOLERANCES UNLESS OTHERWISE STATED
 GENERAL TOLERANCES RIGHT ANGLE BENDS &
 NO DEC. PLACE +/-1.0mm OTHER ANGLES +/-1°
 ONE DEC. PLACE +/-0.3mm MACHINED DIAMETERS
 TWO DEC. PLACE +/-0.1mm CONCENTRIC WITHIN
 +/-0.1mm T.I.R.
 SCREW THREADS ARE ISO METRIC COARSE PITCH
 TOL. 6g/6h (MED. FIT) TO BS3643
 WIRE DIA./PLATE THICKNESS TO COMMERCIAL LIMITS
 GEOMETRICAL TOLERANCING TO BS308 PART 3

NOTES

- MATERIALS OF CONSTRUCTION
 316 STAINLESS 1.4404
 POLYMER CAP/FILLER MESH
 POLYPROPYLENE/RUBBER WHEELS
 PVC HANDLE GRIPS
- ALL DIMENSIONS IN mm
- MASS 52 KG
- USE DATA SHEET 485004800 FOR "MY" SERIES FOUR-WHEEL
 TURNABLE TROLLIES
- MAX LOAD CAPACITY 500KG
- HAND MANEUVERED ONLY, NOT SUITABLE FOR TOWING

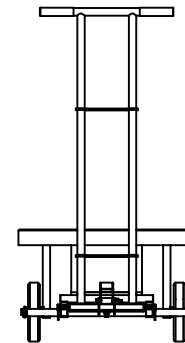
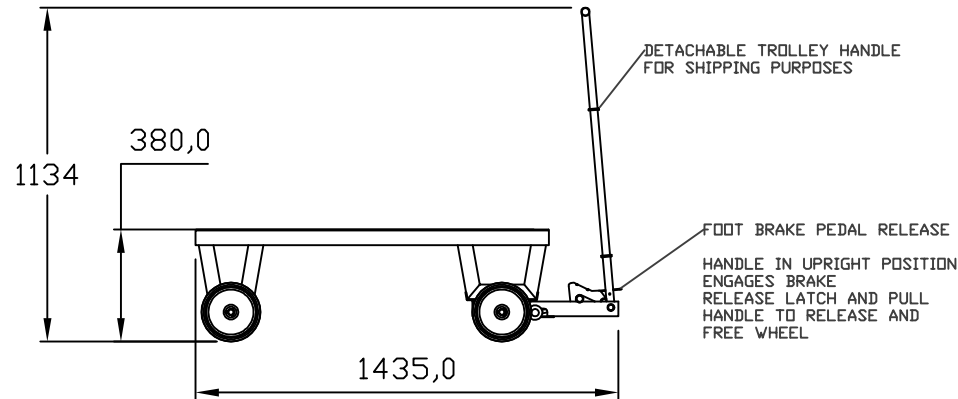
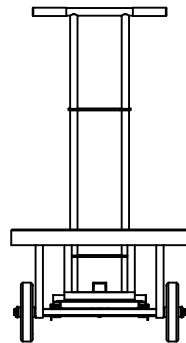
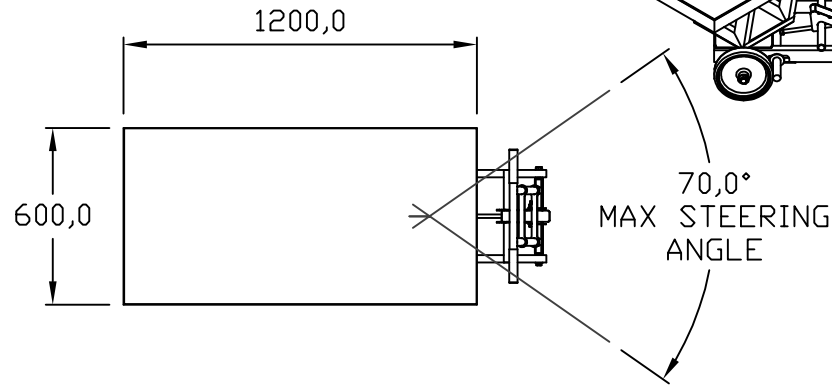
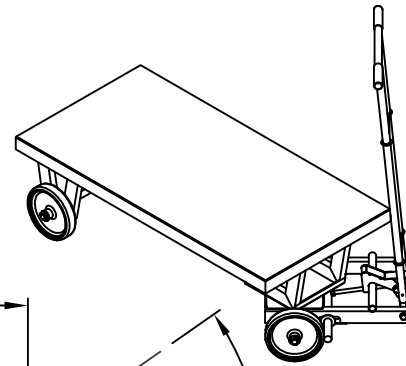
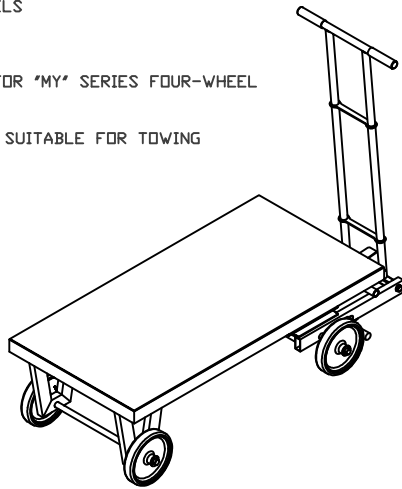

UNLESS OTHERWISE STATED:
 DIMENSIONS IN MILLIMETRES
 SURFACE FINISH IN MICROMETRES
 REMOVE SHARP EDGES

© COPYRIGHT 2023 SARUM HYDRAULICS LTD.



SARUM HYDRAULICS LTD.

SALISBURY, SP4 6EB, UK
 www.sarum-hydraulics.co.uk

TITLE
INSTALLATION DRAWING TURNABLE TROLLEY 1200DECK

DRAWN N.O	APP
	CHKD
SCALE F SIZE	SHEET OF
CAD 2-D	MY-1206-316-PR
DRAWING NO.	MY-1206-316-PR

1	FIRST ISSUE	10/23	MATERIAL PER NOTE
ISSUE	D.C.N.	CHANGE DESCRIPTION & DATE	DATE IMPLEMENTED

FINISH PER NOTE