

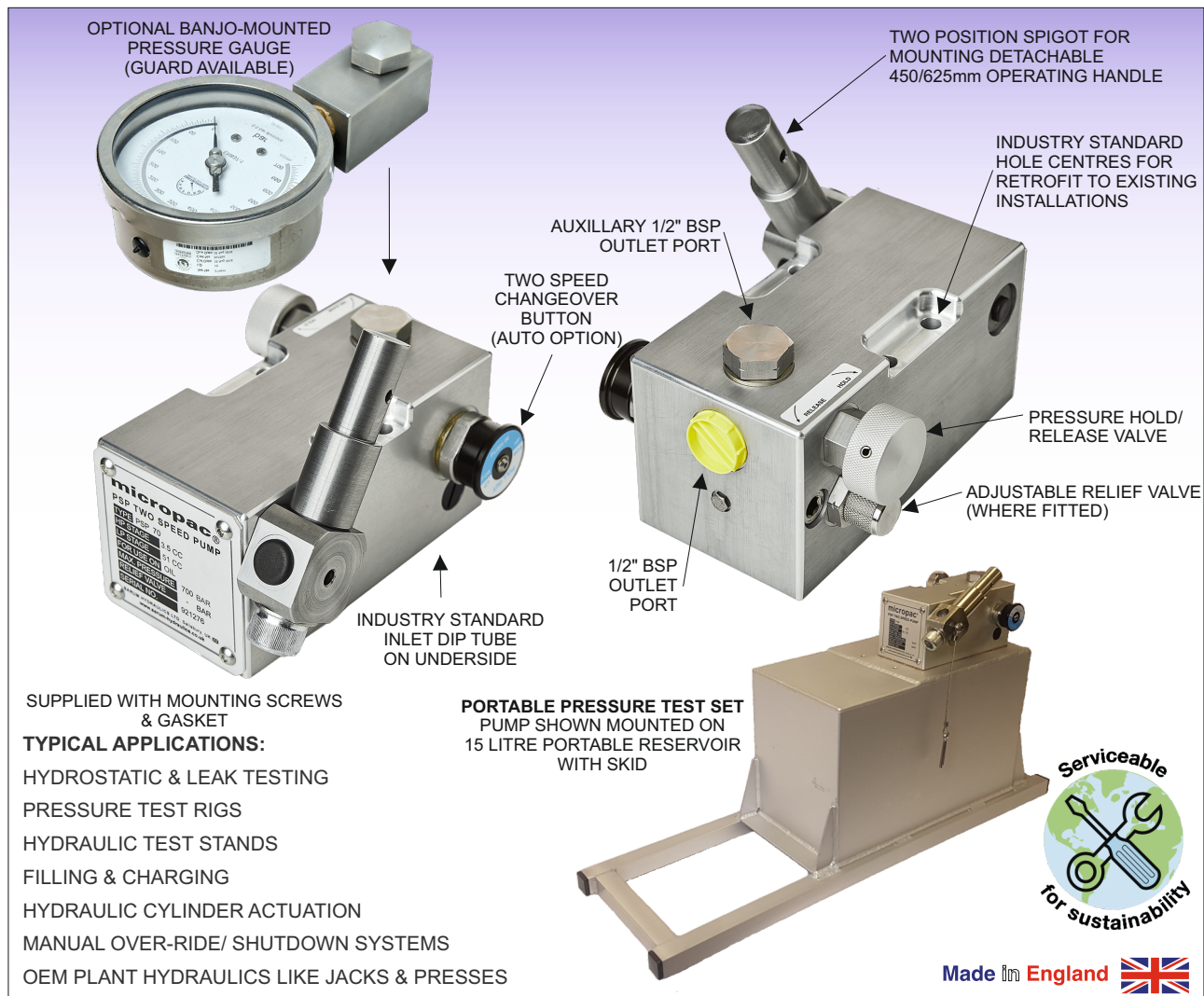

Micropac PSP Series Two Speed Multi-fluid Hydraulic Hand Pump



**A rugged reliable two speed manual changeover hand pump
6 models up to 1000 bar • low corrosion • industry standard retrofit • reservoir available**

FEATURES

- Retrofit 'industry standard' two speed pump
- Reliable- British design & manufacture
- Sturdy construction- indoor & outdoor use
- Compatible with water, oil and other liquids
- Stainless/ anodised alloy wetted parts
- Long life hard chromed stainless piston rods
- Soft-seal check valve for positive sealing
- Polymer valve seats for durability
- User serviceable sealing & seating components
- Rapid fill with push-button changeover valve
- Nitrile seals standard - optional EPDM / Viton
- Universal mounting orientation; 2 position handle
- Single acting - pumps on down stroke only
- Six models for pressures up to 1000 bar
- Optional 15 litre portable reservoir with skid
- Automatic changeover option

INSTALLATION & MAINTENANCE

APPLICATION & MATERIALS OF CONSTRUCTION

This two speed hydraulic hand pump provides enhanced performance by allowing rapid pre-filling at 51cc/stroke up to maximum 50 bar, followed by high pressure operation to 110, 170, 310, 450, 700 or 1000 bar, depending on model. The pump is single acting on the down stroke. There is a push button manual changeover valve to switch between low and high pressure operation. An auto changeover option is offered for OEM applications. Contact the factory.

The wetted parts are manufactured from corrosion resistant anodised aluminium alloy and stainless steel. The handle mechanism is zinc plated steel with detachable stainless steel operating handle.

Soft seat positive sealing check valves make the unit suitable for a wide range of hydraulic fluids, including low viscosity types such as water, water-in-oil emulsions and kerosene. Other valve seats are polyacetal and peek. Standard seals are nitrile rubber. Consult factory on special seal compounds including Viton®, EPDM (typical application- 'Skydrol') and specialist aerospace/process compounds.

SAFETY

When in use, this unit is a component forming part of a hydraulic pressure system. If forming part of a permanent installation, the system should be designed, operated and maintained in accordance with statutory requirements and other relevant instructions. A risk assessment covering safe installation, operation and maintenance should always be carried out prior to use. This product is classified under 'Sound Engineering Practice' of the Pressure Equipment Directive (PED) 2014/68/EU. As such, it does not carry the CE marking.

INSTALLATION & COMMISSIONING

Reservoir mounting: screw inlet tube (length cut to suit) fully into underside of pump. Mount pump & gasket on to reservoir. Retain using 4 x socket cap screws supplied. There are two spot faced G1/2 (G3/8 on the PSP15 high pressure unit) female outlet ports, one on end of pump, the other on top. Top port is flat bottom sealing and suitable for pressure gauge mounting (optional banjo-mounted pressure gauge, range to suit application, available to order). Using a suitable adaptor and sealing washer, make connection to hose/ pipework as required. Where applicable, unused port should be blanked with plug and sealing washer (supplied as standard).

Fit operating handle to handle spigot and operate hand pump to achieve maximum required pressure. Check for leaks in the system. To set relief valve, remove cap, adjust set screw whilst operating hand pump to achieve maximum pressure requirement, then refit cap.

Remote mounting: inlet connection on underside of pump is G3/8 female. If the unit is remotely piped to a reservoir, ensure inlet tube is minimum 10mm bore, not constricted and connection to pump must be leak tight.

MAINTENANCE

The inlet and outlet check valves are easily serviced and utilise replaceable seats. The inlet strainer may be accessed for cleaning through port on side of pump below release/hold knob. Service kits are available comprising all seals, seats, balls and springs.

DIMENSIONS

ALL DIMENSIONS ARE IN MM

WEIGHTS:
PUMP UNIT - 5.6KG
HANDLE (625mm) - 0.7kg
GAUGE & BANJO - 1.8kg

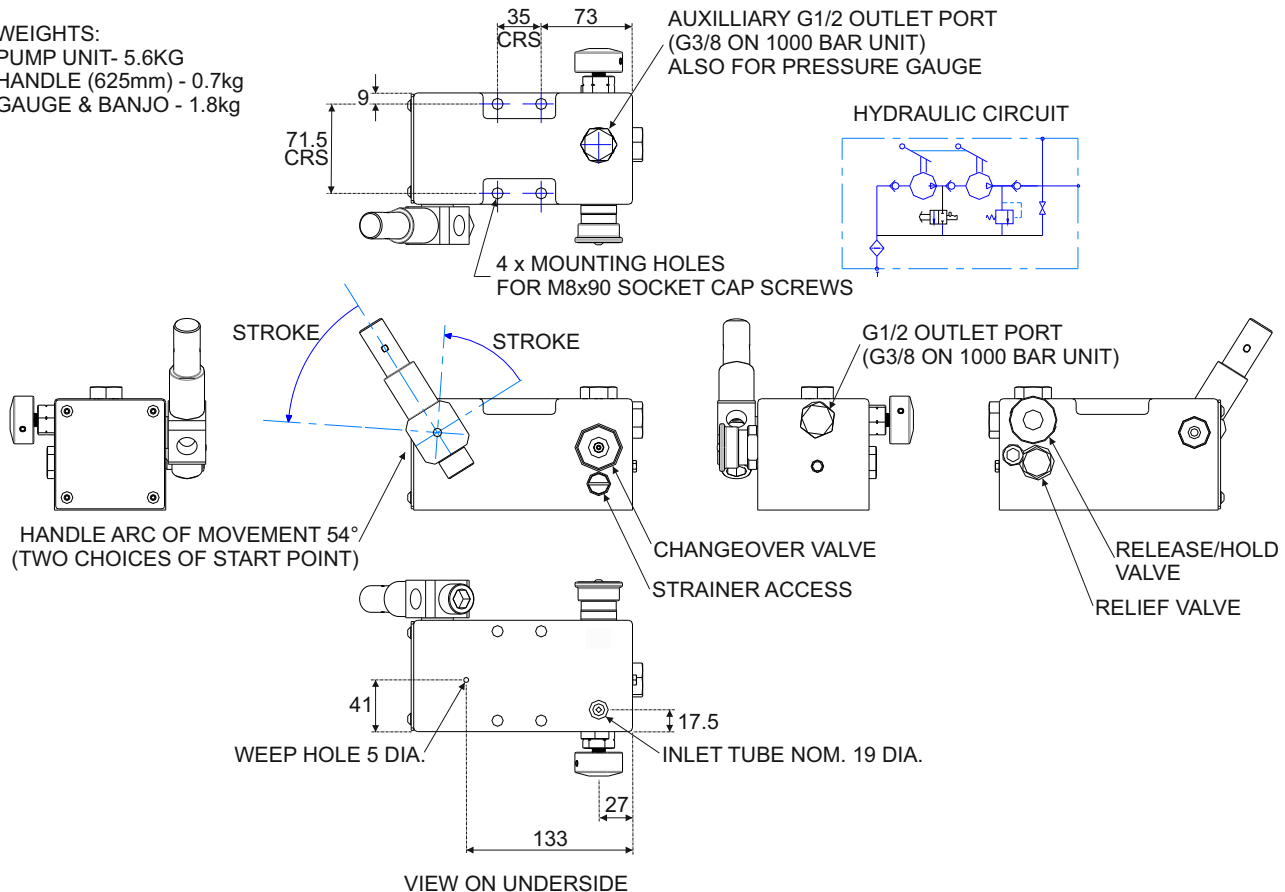

PORTABLE RESERVOIR FOR PSP PUMP

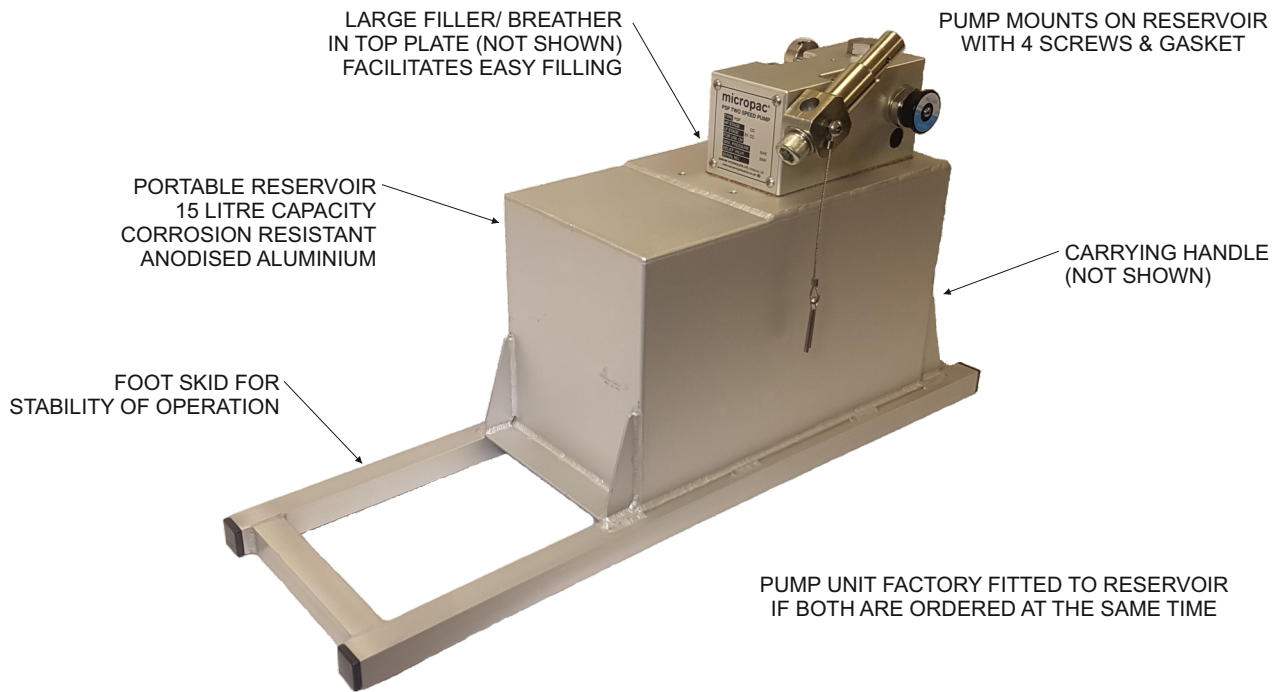

APPLICATION & MATERIALS OF CONSTRUCTION

Reservoir suitable for portable applications. The reservoir is corrosion resistant. Filler/ breather cap constructed from oil resistant plastic.

SAFETY

A risk assessment covering safe installation, operation and maintenance should always be carried out prior to use. This should be carried out in conjunction with the pump unit.

INSTALLATION & COMMISSIONING

Reservoir must be sited on a smooth, flat and firm surface capable of safely withstanding pump operating handle loads. Unscrew filler breather cap, fill reservoir and replace cap after filling.

MAINTENANCE

The filler breather cap has an air filter which is accessible for cleaning.

DIMENSIONS

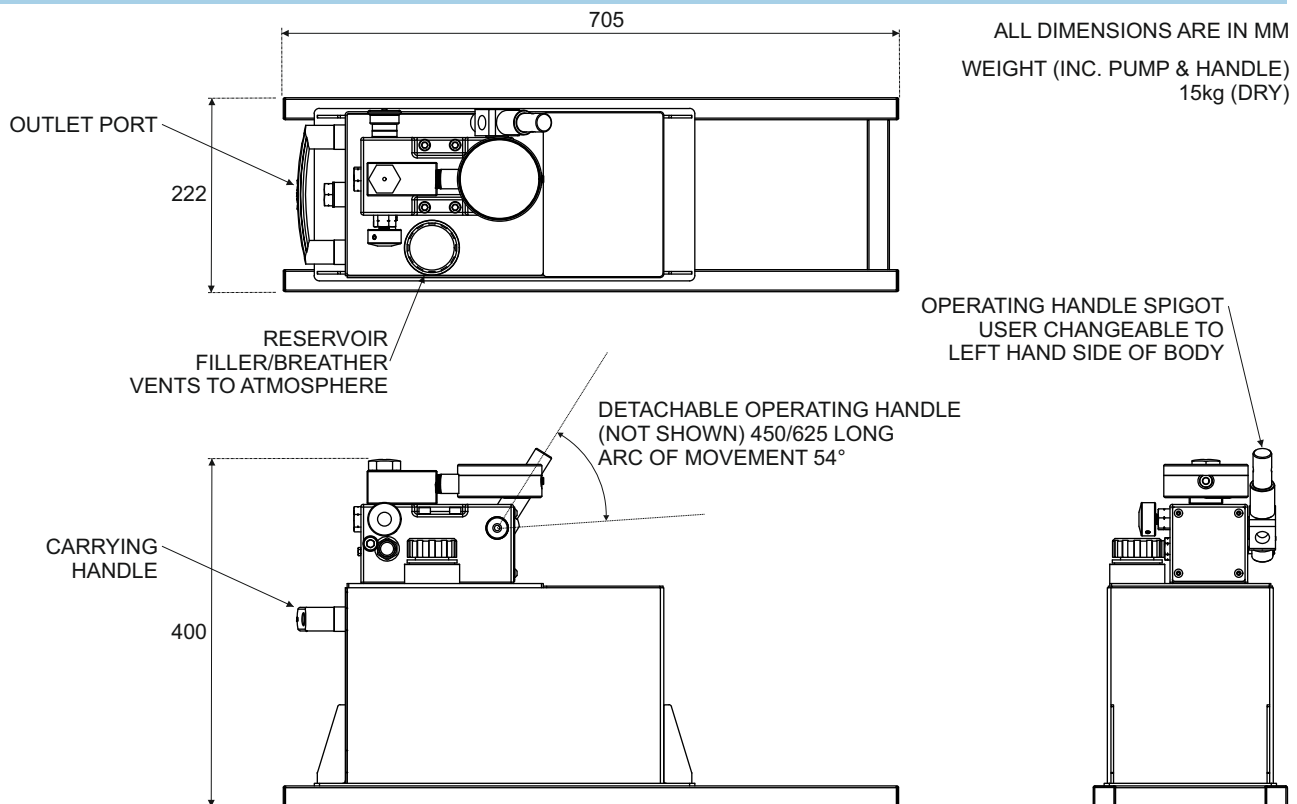

ORDERING CODES FOR PSP PUMP AND RESERVOIR

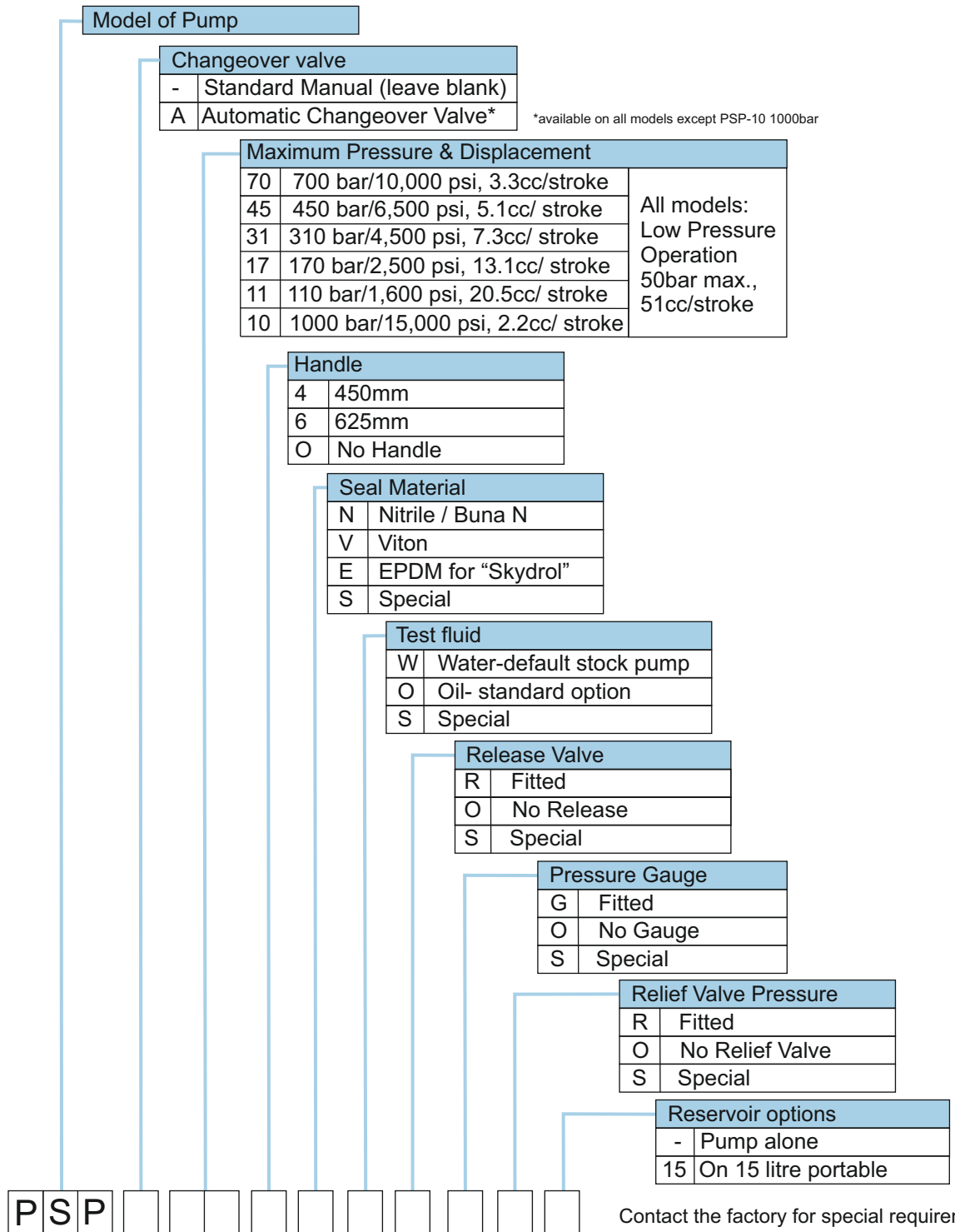

We are a long established ISO 9001 registered designer and manufacturer of hydraulic equipment. Full details of other products in our range are available from:

Sarum Hydraulics Limited
 Unit 1 Danebury Court, Salisbury, SP4 6EB, UK
 Tel: 44(0)1722 328388 Fax: 44(0)1722 414307
 email: pumpsales@sarum-hydraulics.co.uk
 www.sarum-hydraulics.co.uk



SARUM
 HYDRAULICS
 Designers & Manufacturers of Micropac® Hydraulics

We invest heavily and continuously in product development. Specifications are therefore liable to change without prior notification.
 ®Micropac is a Registered Trade Mark of Sarum Hydraulics