



Micropac® MPM series Sub-compact Hydraulic Hand Pump Modules

Made in England 

TWO SPEED UNIT:
RESERVOIR CAPACITY 120cc

SINGLE SPEED UNIT:
RESERVOIR CAPACITY 50cc

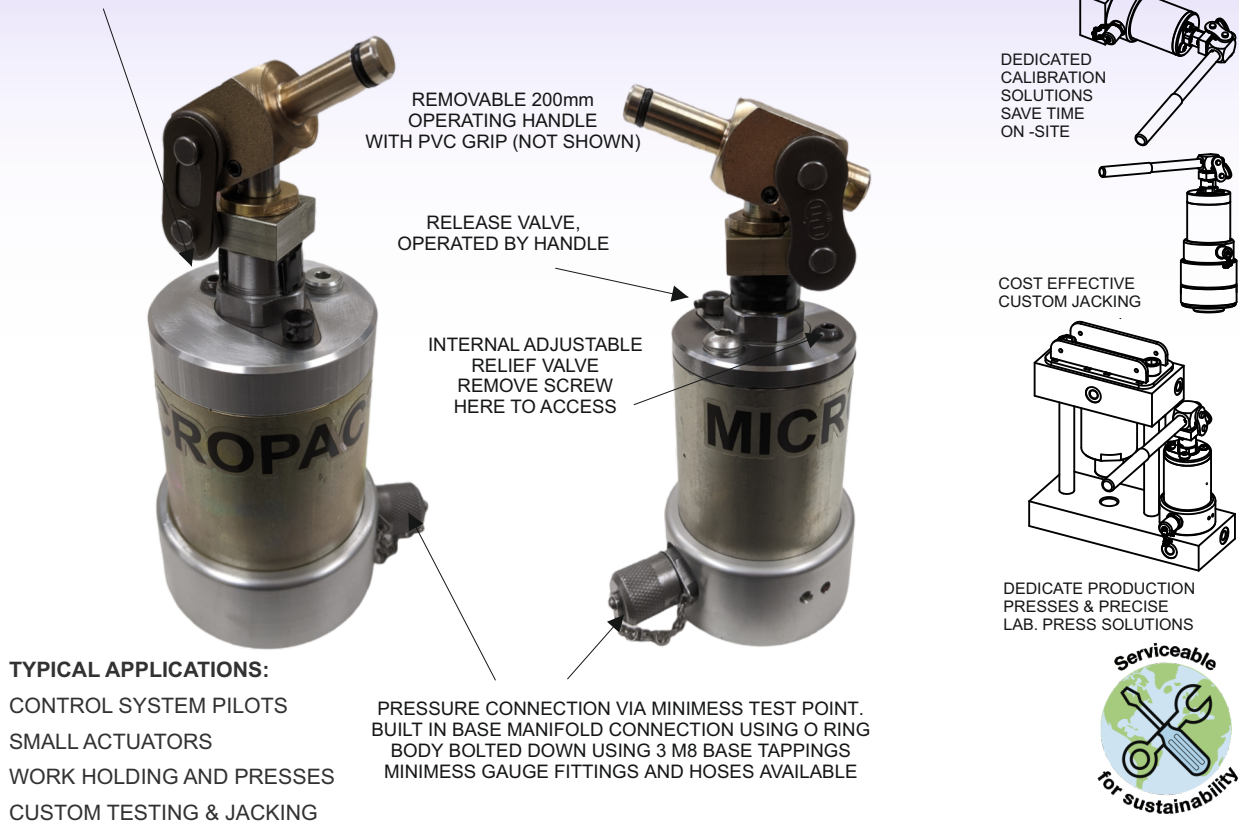

REMOVABLE 200mm OPERATING HANDLE WITH PVC GRIP (NOT SHOWN)

RELEASE VALVE, OPERATED BY HANDLE

INTERNAL ADJUSTABLE RELIEF VALVE REMOVE SCREW HERE TO ACCESS

TYPICAL APPLICATIONS:
CONTROL SYSTEM PILOTS
SMALL ACTUATORS
WORK HOLDING AND PRESSES
CUSTOM TESTING & JACKING

PRESSURE CONNECTION VIA MINIMESS TEST POINT. BUILT IN BASE MANIFOLD CONNECTION USING O RING BODY BOLTED DOWN USING 3 M8 BASE TAPPINGS MINIMESS GAUGE FITTINGS AND HOSES AVAILABLE

TYPICAL APPLICATIONS

DEDICATED CALIBRATION SOLUTIONS SAVE TIME ON-SITE

COST EFFECTIVE CUSTOM JACKING

DEDICATE PRODUCTION PRESSES & PRECISE LAB. PRESS SOLUTIONS



**Ultra compact 630 bar pumps with sealed hydraulic systems
Proven hydraulic power for your hydraulic tool solution.**

FEATURES

- Ultra low space envelope
- Single & two speed models up to 630bar
- Adjustable internal pressure relief valve
- Sealed reservoir for universal orientation
- Single acting operation - pumps on down stroke
- Hard chromed piston rod for long life
- British designed and manufactured
- Robust steel & aluminium construction
- 360 degree Handle swivel for ease of use
- Base mount or side "Minimess" connections
- Operating temperature range -20°C to 80°C
- Same mounting footprint for single or two speed
- Integrated inlet and outlet check valves
- Factory support for application and use

INSTALLATION & MAINTENANCE

APPLICATION

The unit is suitable for any application requiring manual generation of hydraulic power e.g. control system pilots, small actuators or calibration. The small displacement from this compact unit will limit application in larger systems. The single speed unit has a reservoir capacity of 50cc and the dual speed unit has 120cc. The single speed unit has the same displacement over its whole pressure range up to 620 bar. The two speed unit has a rapid pre-fill then automatically changes to a small displacement low handle load high pressure stage.

The unit is suitable for use with mineral oil and other similar viscosity fluids. Standard seals are nitrile rubber - check compatibility for medium. If in doubt, consult factory. For low viscosity liquids, we recommend use of our MW series hand pumps with a poppet instead of ball check valves, rather than the MPM series.

The body is tapped M8 in three places on the base for mounting. The holes are equi-spaced on a circle, so the unit can be orientated in three positions to suit an application. These holes must not be drilled out or otherwise modified. The hydraulic outlet is by means of a port on the centre of the base face, sealed by an O ring or by means of the Minimess coupling in the G1/8 port on the side of the body. See "connections." Because of the sealed hydraulic system, the units can be used in any orientation and do not need to breath to atmosphere. The sealed hydraulic system will eliminate leakage of oil. As with any small volume sealed hydraulic reservoir, the final system needs bleeding, refilling and testing before it is put into use.

MATERIALS

Both the single and dual speed units are manufactured in anodised alloy and carbon steel. There is no stainless steel option.

SAFETY

This unit is a component forming part of a hydraulic pressure system. If forming part of a permanent installation, the system should be designed, operated and maintained in accordance with statutory and regulatory requirements, and other relevant instructions.

Whether you are using the pressurised base port or simply fixing the pump down using the M8 tapped holes, you must use all three fixings. The interface must be flat and if you are using the base hydraulic port with the o ring seal, the finish must be 1.6 micron minimum.

CONNECTIONS

Make connection to the "Minimess" connector using a microbore hose. Alternatively, pressure connection may be via a counterbore on the base of the unit, sealed with an o ring. A grub screw is removed and a ball expelled to open up this port. Three M8 screws will be used to secure the mating face to the Micropac MPM pump body using the tapped holes. The Minimess port is G1/8 and potentially the unit can be operated to 700 bar with the connector removed. You can make the hydraulic connection to the base yet connect a pressure gauge to the Minimess coupling. Solid mount using the M8 fixings. Contact the factory to discuss your application.

COMMISSIONING

Remove the M8 button head screw in the top cap and One M6 screw. Fill reservoir through the M8 port and allow air to bleed out through the M6. Ensure air is expelled from the furthest or highest point on your hose or cylinder. Final bleeding is achieved by pressurising your cylinder or system, topping up the reservoir with oil, refilling the plugs loosely and letting air bubbles escape. Plugs are then tightened. Any sealed system does need extra care in purging out all the air. Operate hand pump and prime system. Pressurise to maximum pressure. Check for leaks in the system. Set relief valve using a 3mm a/f key through the M6 filler plug to suit your system.

MAINTENANCE

Maintenance operations should only be carried out by a competent service engineer.

The inlet strainer is inside the reservoir and as the system is sealed, should only need cleaning during service. Service kits are available.

Sarum Hydraulics Ltd also offer a servicing facility; please advise before returning the unit to us.

SPECIFICATION

Displacement/ double stroke: 0.6cc (HP)
1.2cc (LP - 2 speed only)

Compatibility: mineral oil

Max. operating pressure: 700 bar (without Minimes)
630 bar (with Minimes)

Ambient operating temperature range: -20 to 40°C

Media operating temperature range: -35 to 80°C

Nom. operating hand load: 208N @ 630 bar

Weight: 2kg (approx.)

DIMENSIONS, SINGLE SPEED

DIMENSIONS IN mm

FOR FURTHER DETAIL,
SEE INSTALLATION DRAWINGS;
CONTACT FACTORY OR
DOWNLOAD FROM WEBSITE

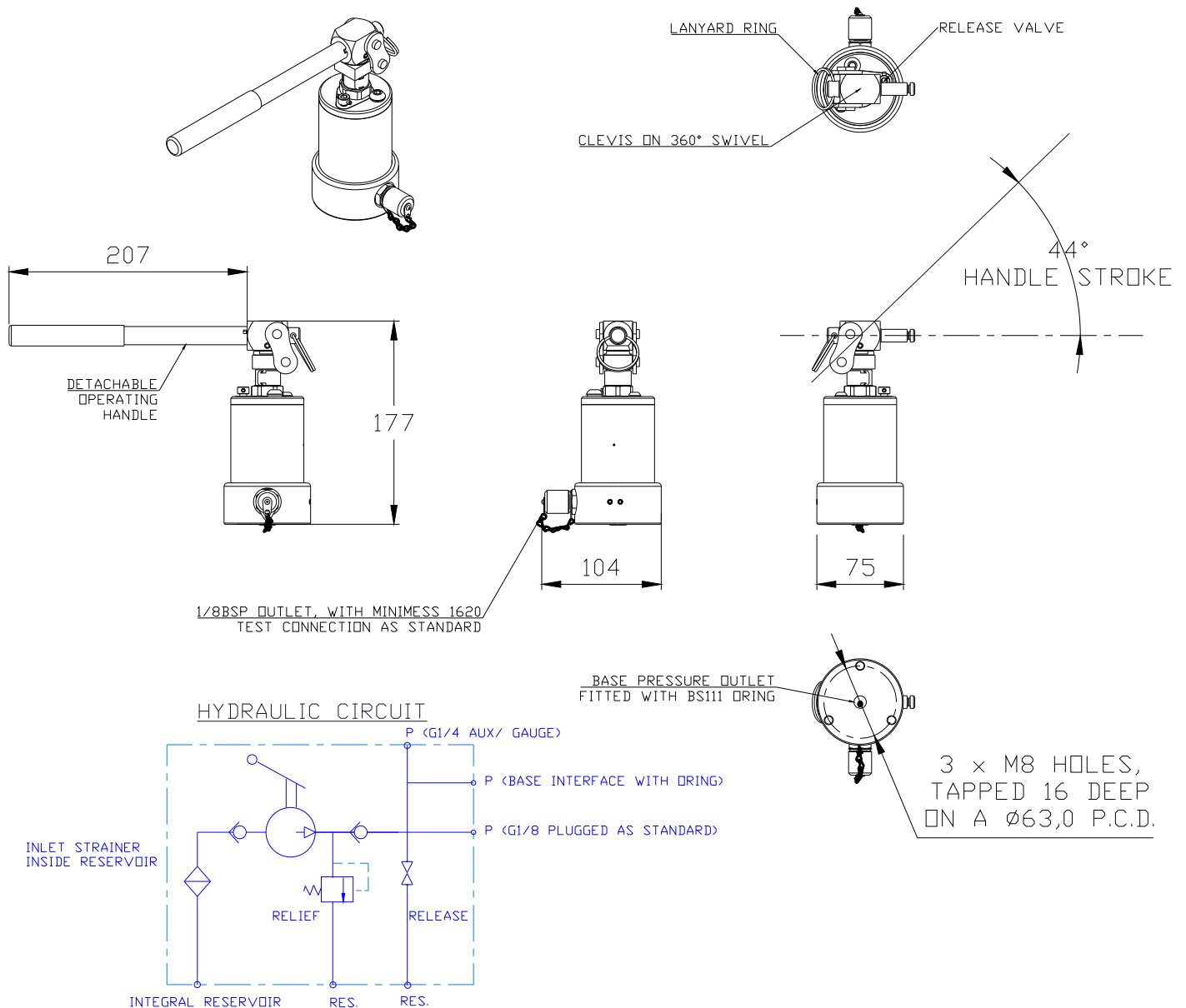

DIMENSIONS, TWO SPEED

DIMENSIONS IN mm

FOR FURTHER DETAIL,
SEE INSTALLATION DRAWINGS;
CONTACT FACTORY OR
DOWNLOAD FROM WEBSITE

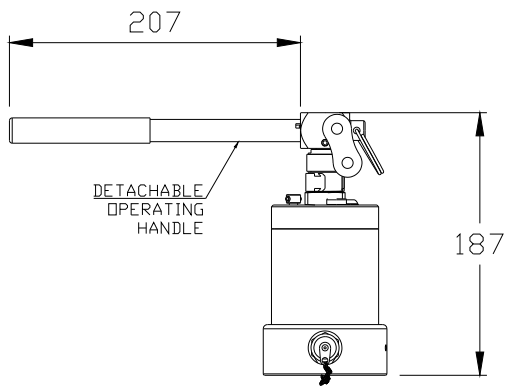
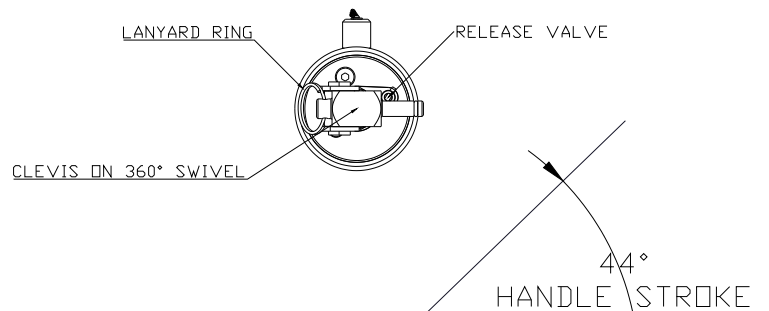
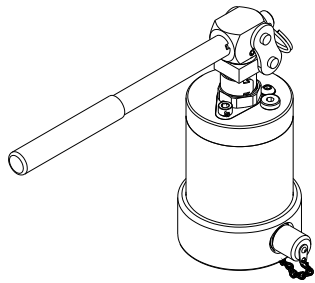

1/8BSP OUTLET, WITH MINIMESS 1620
TEST CONNECTION AS STANDARD

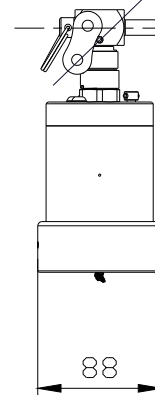
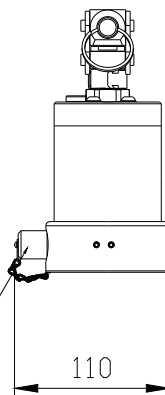

HYDRAULIC CIRCUIT

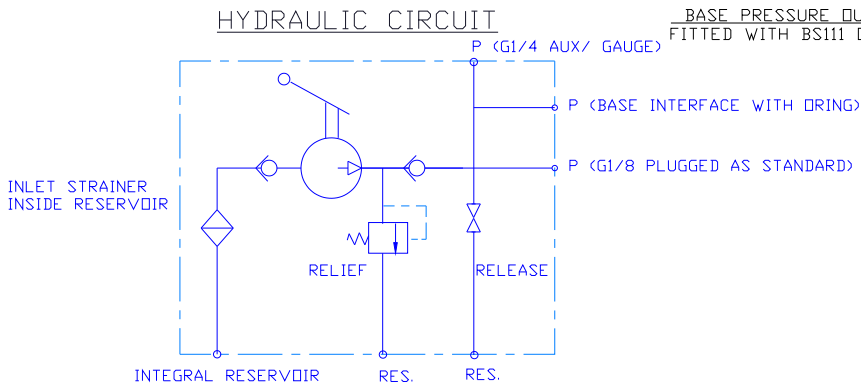

BASE PRESSURE OUTLET
FITTED WITH BS111 DRING

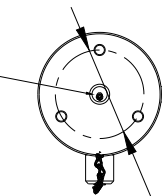

3 x M8 HOLES,
TAPPED 16 DEEP
ON A Ø63,0 P.C.D.

ORDERING CODE

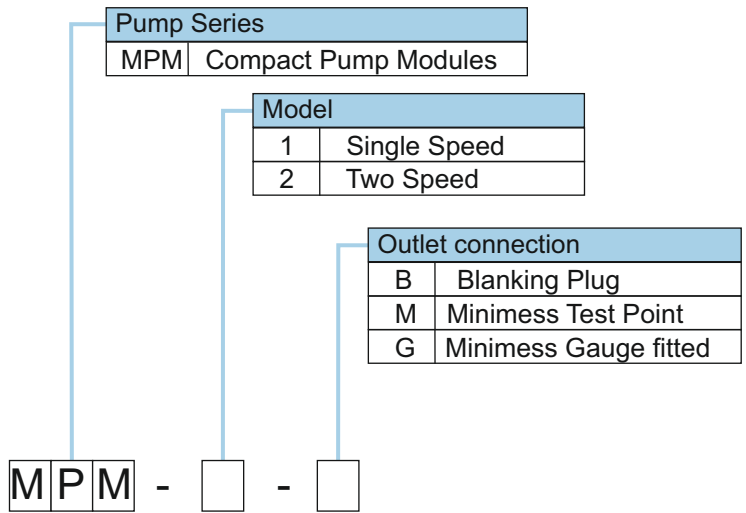

We are a long established ISO 9001:2015 certificated designer and manufacturer of hydraulic equipment. Full details of other products in our range are available from:

Sarum Hydraulics Limited
 Unit 1 Danebury Court, Salisbury, SP4 6EB, UK
 Tel: 44(0)1722 328388 Fax: 44(0)1722 414307
 email: pumpsales@sarum-hydraulics.co.uk
 www.sarum-hydraulics.co.uk



SARUM
HYDRAULICS
 Designers & Manufacturers of Micropac® Hydraulics

We invest heavily and continuously in product development.
 Specifications are therefore liable to change without prior notification.
 ®Micropac is a Registered Trade Mark of Sarum Hydraulics