

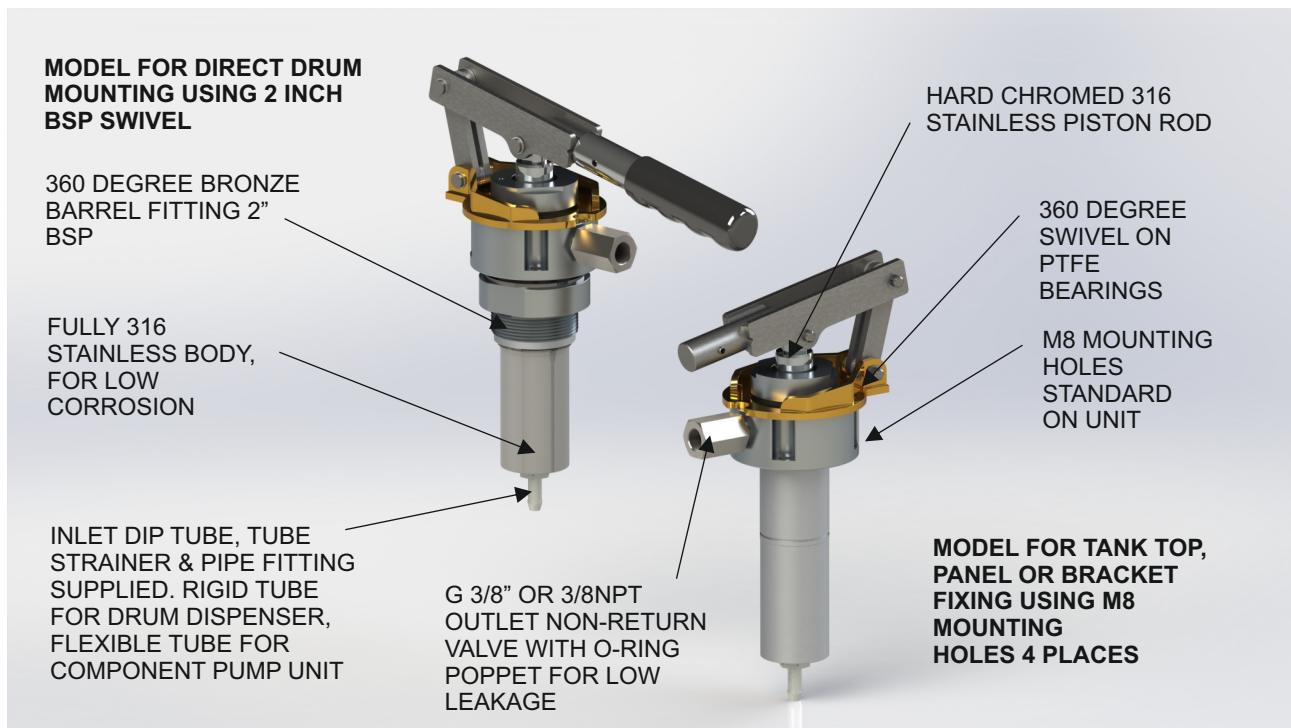

Micropac MB series Hand Pumps and Drum Pumps

Versatile low pressure high flow pumps in 316 1.4404 stainless and polymer for long life and low corrosion.



TYPICAL APPLICATIONS: LOW PRESSURE FLUID DISPENSING DIRECT FROM A DRUM, RESERVOIR OR REMOTELY PIPED SUPPLY. FILLING OF SYSTEMS, CHARGING, FLUSHING SYSTEMS, LUBRICATION AND OILING. ACID AND ALKALI DRUM PUMP, PETROLEUM, OFFSHORE AND MARINE, HIGH IGNITION RISK ENVIRONMENTS INCLUDING ATEX PUMPS MULTI FLUID USE ON "SKYDROL" AND OTHER SPECIALIST MEDIA. SEALS EASILY CHANGED

FEATURES

- Suitable for offshore / marine environments
- 316 stainless and polymer construction
- Rugged construction with dirt excluder
- Oil, Water, Glycols and other fluids
- Hard chrome plated 316 piston rod for long life
- Poppet outlet check valve for very low leakage
- Soft seat inlet and piston valves for reliability
- All valve seats replaceable for long service life
- Swivel options for a range of containers/drums
- Drum, panel mount or pump alone
- 100cc / double stroke to 25 bar, to 4 litres/min
- Double acting - pumps on up and down stroke
- Nitrile seals standard - optional EPDM / Viton®
- 360 degree barrel swivel in bronze "S" unit
- ATEX version available for hazardous areas
- No relief or release valves fitted
- Hand pump module available without drum swivel
- Inlet tube connector

INSTALLATION & MAINTENANCE

APPLICATION

The unit provides manual hydraulic pumping and dispensing for a range of applications and on multiple fluids including glycols and skydrol. Because of our use of soft seat and poppet valves the unit is suitable for hydraulic fluids including low viscosity types such as water-in-oil emulsions and offshore control liquids. Standard seals are nitrile rubber. Consult factory for special seal requirements for other fluids, including Viton®, EPDM and specialist aerospace / process compounds.

Note this unit does not feature an integrated hold / release valve, relief valve or pressure gauge. These components would be added if the unit is used for applications other than low pressure dispensing.

MATERIALS

The materials of construction are 316 stainless steel and polymer. Seals are PTFE, UHMWP and Nitrile.

The barrel swivel if fitted is CW307G bronze.

DISPLACEMENT

The unit is available as a 100cc per double stroke/ 25 bar version. The maximum free flow is approximately 4 lpm.

COMMISSIONING

Operate hand pump and pressurise to maximum pressure. Check for leaks in the system.

CONNECTIONS

The unit has a G3/8" or 3/8NPT female thread on the outlet port. Other fittings are available. Make a connection to this with an appropriate adaptor or fitting.

The inlet hose is fitted with a 12mm compression fitting/rigid dip tube/inlet strainer on drum units or a 12mm hose tail and flexible dip tube/strainer on tank top pump. A 12mm standpipe is available for the pump unit as an option. For drum units, the bronze drum plug is screwed into the 2 inch BSP drum fitting.

MAINTENANCE

The inlet and outlet check valves are easily serviced and use replaceable seats. Service kits are available comprising all seals, seats, balls and springs.

SAFETY

This pump is a component forming part of a hydraulic pressure system. The system should be designed, operated and maintained in accordance with statutory requirements and other relevant instructions.

DIMENSIONS

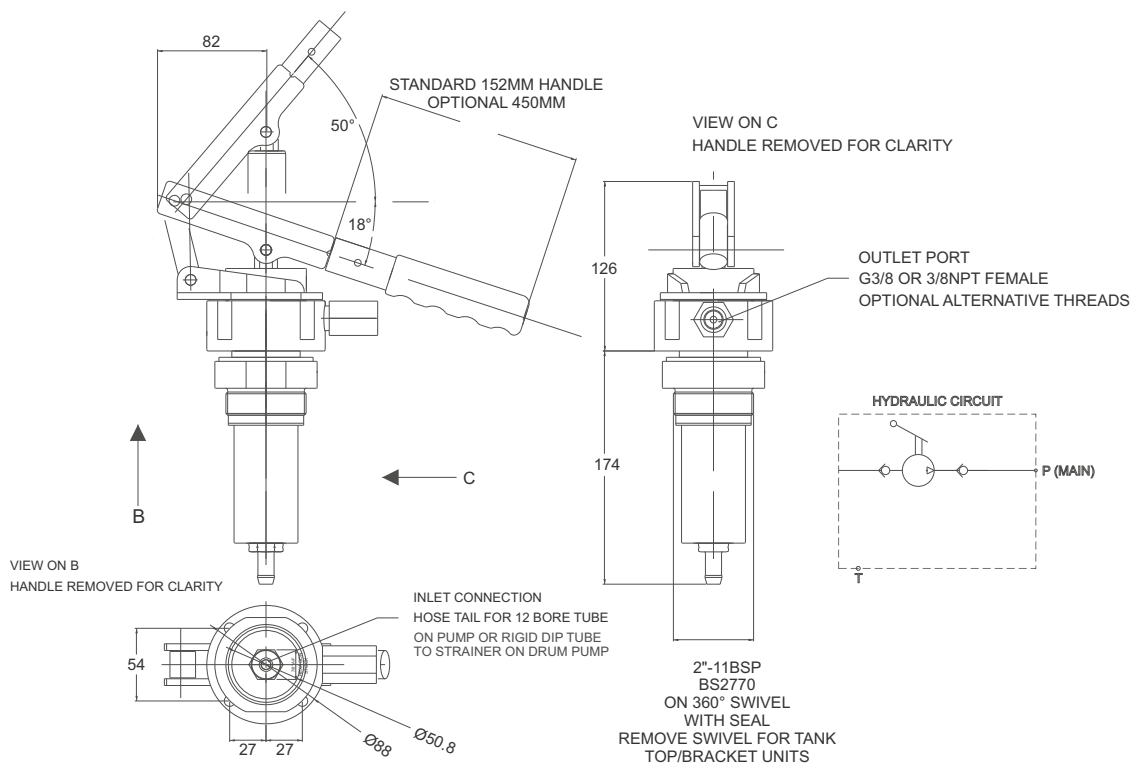

We are long established ISO 9001 designers and manufacturers of hydraulic equipment. Full details of other products in our range are available from:

Sarum Hydraulics Limited
Unit 1 Danebury Court, Salisbury SP4 6EB, UK
Tel: 44(0)1722 328388 Fax: 44(0)1722 414307
email: pumpsales@sarum-hydraulics.co.uk
www.sarum-hydraulics.co.uk



SARUM
HYDRAULICS
Designers & Manufacturers of Micropac® Hydraulics

We invest heavily and continuously in product development. Specifications are therefore liable to change without prior notification.

®Micropac is a Registered Trade Mark of Sarum Hydraulics



ORDER SHEET FOR MICROPAC 316 STAINLESS DRUM PUMP

Model of Pump	
Materials of construction	See page 2 for full materials description
6 316 Stainless	
Displacement	
10 100cc / 25 BAR	
Handle	
4 450mm Short	
6 625mm Long	
1 150mm Handle	
0 No Handle	
Seal Material	
N Nitrile / Buna N	
V Viton/fluorocarbon	
E EPDM for Skydrol	
S Special	
Test Fluid	
W Water	
O Mineral Oil	
S Special	
Outlet port	
G G3/8 BSP female	
N 3/8NPT female	
Pump Configuration	
S Swivel G2" for drum	
P Panel mount c/w bracket	
A Low pressure pump alone	
ATEX Certification	
- Standard unit	
AX ATEX Compliant	

M B 6 1 0 [] [] [] [] [] [] [] [] [] []

For special options, please consult factory.

Note this unit does not feature an integrated hold / release valve, relief valve or pressure gauge. If these are required, our MW series may be more suitable. Consult the data sheet or contact the factory if you have an application to discuss.

Sarum Hydraulics Limited
Unit 1 Danebury Court, Salisbury SP4 6EB, UK
Tel: 44(0)1722 328388 Fax: 44(0)1722 414307
email:pumpsales@sarum-hydraulics.co.uk
www.sarum-hydraulics.co.uk