

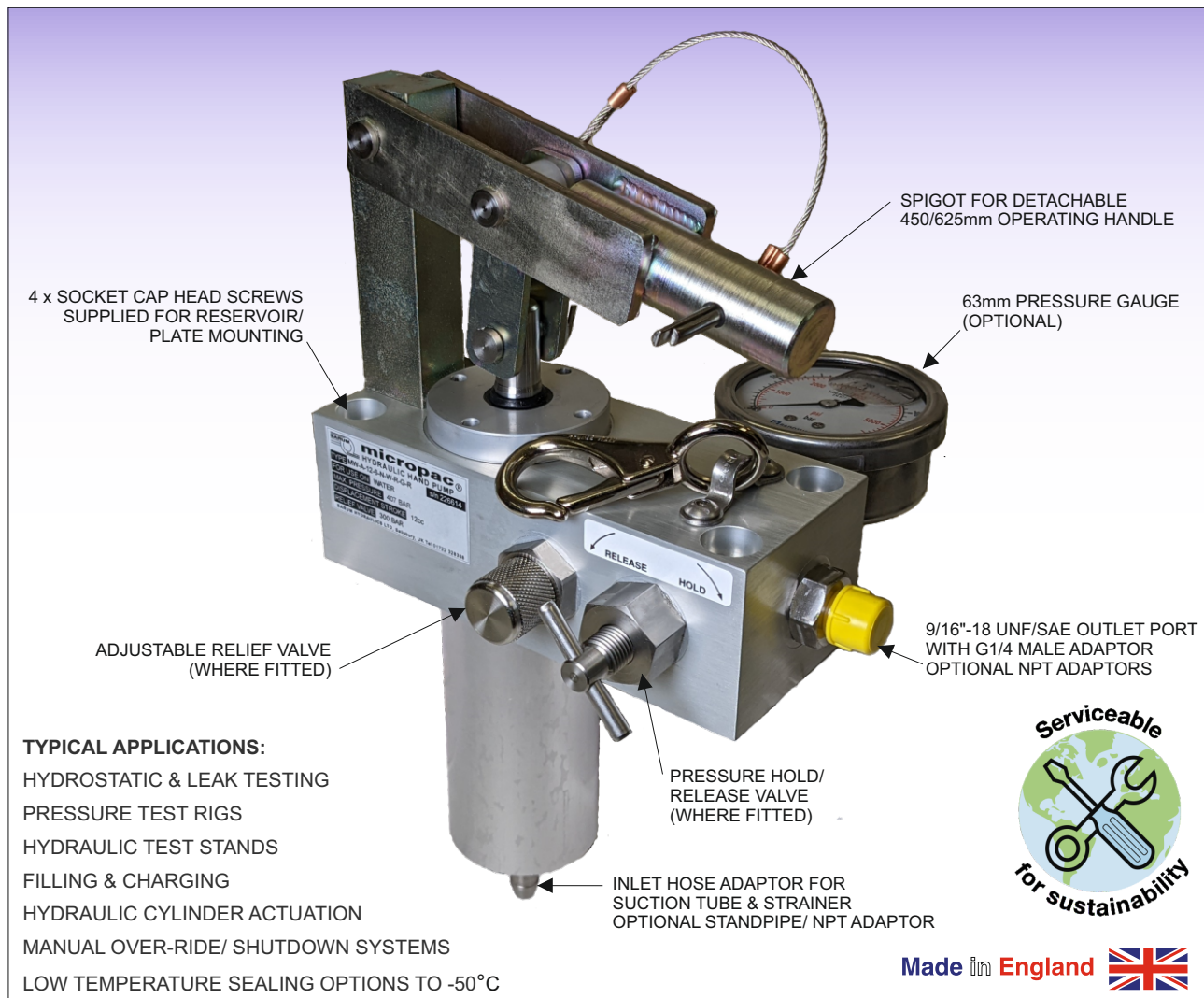

Micropac® MW-A Single Speed Anodised Alloy Hydraulic Hand Pump



A quality engineered light weight hand pump for the professional FEATURES

- Double acting - pumps on up and down strokes
- Anodised aluminium/ stainless steel wetted parts
- Four models cover max. pressures 50 - 400 bar
- Compatible with water, oil and other liquids
- Reliable- British design & manufacture
- Sturdy construction- suitable for outdoor use
- Long life hard chromed stainless piston rod
- Dirt excluder and PTFE low friction sealing
- Soft-seat check valve for positive sealing
- Pressure gauge, release & relief valve options
- User serviceable sealing & seating components
- Detachable 450mm or 625mm operating handle
- Nitrile seals standard - optional EPDM/ Viton®
- Universal mounting orientation
- Optional range of alloy fixed mounting reservoirs
- Factory support for product and application

INSTALLATION & MAINTENANCE

APPLICATION

This equipment is suitable for use in both indoor and outdoor applications; for extreme environments, see our MW-3 stainless steel hand pumps. A range of anodised aluminium reservoirs is also available.

The hydraulic hand pump provides manual hydraulic power for a range of applications such as manual back up systems and hydrostatic testing. It is fitted with a soft seat outlet check valve and is thus ideal for leak testing. Pumping operation is double acting; fluid is displaced on both the up and down strokes.

The pump is available in 4 displacement per double stroke/ maximum pressure ranges; 12cc/400 bar, 25cc/ 200 bar, 49cc/ 100 bar, and 100cc/ 50 bar.

Sealing options are nitrile, fluorocarbon and ethylene propylene elastomers, specified at time of ordering.

Depending on specification, the pump may be fitted with a soft seat pressure hold/ release needle valve, an adjustable pressure relief valve, and a pressure gauge.

The stainless steel operating handle is detachable and measures 450mm or 625mm.

The pump is intended for direct mounting onto a suitable reservoir, but can also be remote mounted and piped into a system- contact factory for connection options.

MATERIALS

The materials of construction are anodised aluminium alloy 6082T6, plated carbon steel, aluminium bronze, small amounts of stainless steel 302/303/304/420/431, UHMWP, PTFE and elastomeric sealing.

SAFETY

This unit is a component forming part of a hydraulic pressure system. If forming part of a permanent installation, the system should be designed, operated and maintained in accordance with statutory requirements and other relevant instructions. A risk assessment covering safe installation, operation and maintenance should always be carried out prior to use.

Under the EU Pressure Equipment Directive (PED) 2014/68/EU and the UK Pressure Systems (Safety) Regulations, the unit is not required to be CE or UKCA marked.

INSTALLATION

The pump can be mounted vertically or horizontally; the pump inlet has to be fully immersed in the pumped media at all times.

Reservoir mounting: refer to pump dimensions section for mounting interface detail. The reservoir top plate requires cut outs for the pump barrel, relief and release drain ports and four M8 tapped holes for pump mounting. The reservoir should be vented to atmosphere. Cut the pump dip tube and filter assembly to suit your reservoir. The inlet hose connector is designed to accept 9.5mm i.d. nylon tube (12mm i.d. on 100cc units). Push the tube onto the barbed pump inlet. Locate the mounting gasket supplied with the pump onto the reservoir top plate such that the release/relief valve drain holes align. No jointing compound is necessary.

INSTALLATION continued

Lower the pump into position and secure using the four M8 x 65 long socket head cap screws supplied, tighten evenly to a torque of 15Nm.

Before mounting the reservoir, consider ergonomics of pump handle operation; refer to pump dimensions section.

Mount the reservoir on a surface that can withstand handle forces during pumping to maximum required pressure. Use the mounting holes provided; fixings are not supplied.

Remote mounting: mounting detail as for reservoir. Make connection to inlet using suitable coupling, ensuring media is filtered. Drain connections are 1/8NPT where used.

CONNECTIONS

The outlet connection is a 9/16" UNF SAE female port (G3/8 on 7cc/ 700 bar unit); a G1/4 male 60° coned adaptor is fitted as standard.

Make connection to system using suitable swivel nut & nipple, or female adaptor fitting.

The pressure gauge port is G1/4 flat bottomed and is plugged where a pressure gauge is not supplied.

COMMISSIONING

The reservoir may be filled by unscrewing the filler cap and topping up to desired level with clean fluid; do not over fill. Where fitted, use the dipstick to determine fluid level. Always refit filler cap after top up.

Fit operating handle to handle spigot. If fitted, close the soft seat release/ hold valve by screwing knob in fully clockwise; do not overtighten. Operate the handle by moving up and down until maximum required pressure is achieved. Check for leaks in the system.

To release pressure, unscrew release/ hold valve knob, slowly for a controlled release.

To set relief valve, remove cap, adjust set screw whilst operating hand pump to achieve maximum pressure requirement, then refit cap.

MAINTENANCE

Maintenance operations should only be carried out by a competent service engineer.

The inlet and outlet check valves are serviceable and employ replaceable seats. Service kits are available comprising all seals, seats, balls and springs.

The pump inlet strainer should be checked periodically for fouling. To do this, the pump should be removed from the reservoir; ensure that the mounting gasket is in good condition when refitting, and that the pump mounting screws are sufficiently tightened to effect a seal between the pump and reservoir.

The reservoir fluid should be kept clean.

If using aqueous media, ensure that the reservoir is protected from low temperatures to prevent against risk of freezing.

Sarum Hydraulics Ltd also offer a servicing facility; please advise before returning the unit to us.

DIMENSIONS

ALL DIMENSIONS IN mm

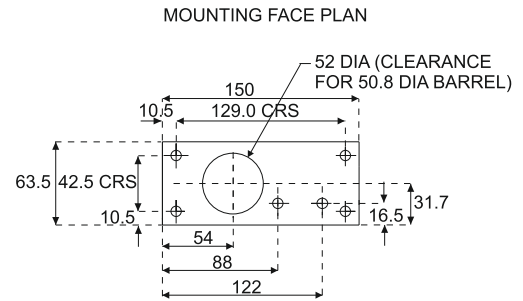
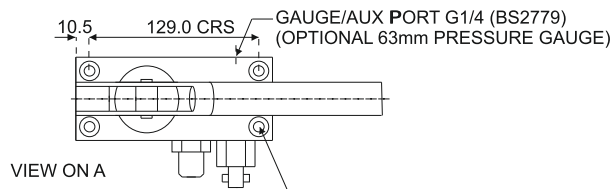

MOUNTING HOLES 8 THRO' FOR M8 SCREWS (SUPPLIED)
RECOMMENDED TIGHTENING TORQUE: 15Nm

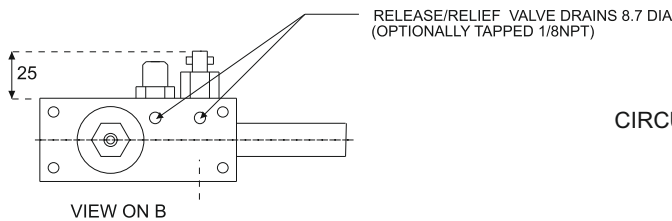
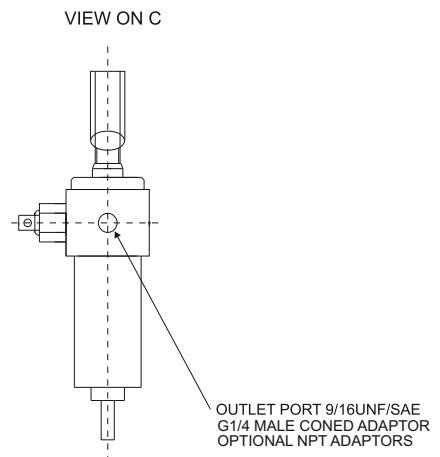
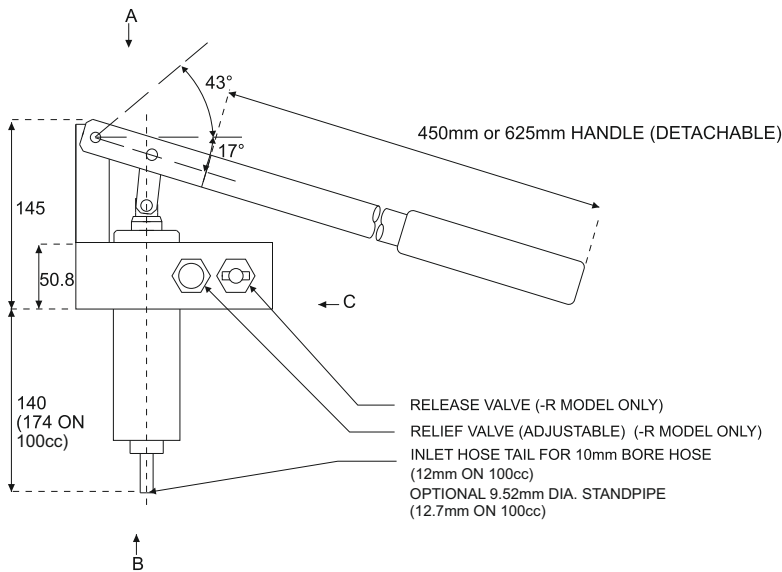

CIRCUIT DIAGRAM- RELEASE AND RELIEF VALVES SHOWN

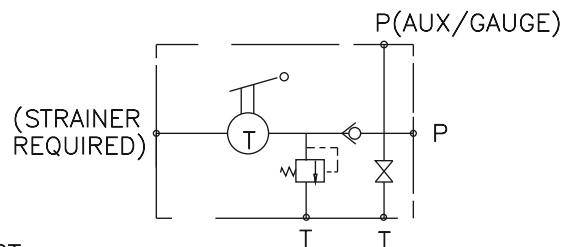

INSTALLATION DRAWING 007000200 AVAILABLE UPON REQUEST

SPECIFICATION

Displacement/ double stroke, max. operating pressure:

MW-A-12: 12cc, 400 bar/6000psi

MW-A-25: 25cc, 200 bar/3000psi

MW-A-49: 49cc, 100 bar/1500psi

MW-A-100: 100cc, 50 bar/750psi

Max. flow (typical):

12cc/stroke = 0.5 litres/ minute (0.7 cu.in./stroke)

25cc/stroke = 1 litre/ minute (1.5 cu.in./stroke)

49cc/stroke = 2 litres/ minute (3 cu.in./stroke)

100cc/stroke = 4 litres/ minute (6.1cu.in./stroke)

Nom. operating hand load (625mm, at max. pressure): 460N

Compatibility: water, water-glycol, mineral oil (nitrile seals).
Fluorocarbon and EPDM sealing options- check compatibility first; if in doubt, consult factory.

Ambient operating temperature range: -20 to 40°C

Media operating temperature range:

Nitrile: -35 to 80°C, Fluorocarbon: -26 to 80°C

EPDM: -50 to 80°C, low temperature options to -50°C

Weight: 4kg

For reservoir specifications, please refer to our MR reservoir datasheet ref. 001026300.

ORDERING CODES FOR MW-A PUMP AND RESERVOIR

Model	
MW	Pump with/ without fixed reservoir

If you require a PORTABLE RESERVOIR, for your MW-A pump, please see our MP range data sheet for 5-20L carry-round and 10/20/50L 2 wheel trolley units.

Body material	
A	Anodised aluminium

Displacement/ max. pressure			
12	12cc /400 bar	25	25cc / 200 bar
49	49cc / 100 bar	10	100cc/ 50 bar

Operating handle	
4	450mm long
6	625mm long
O	No handle

Seal material			
N	Nitrile	E	EPDM
V	Viton		

Test fluid			
W	Water	K	Kerosene
O	Oil	S	Special

Release valve	
O	Not fitted
R	Fitted

Pressure gauge	
O	Not fitted
G	Fitted (range to suit)

Relief valve	
O	Not fitted
R	Fitted (relief pressure to suit)

Reservoir	
	Blank= no reservoir
01	1 litre fixed (316 stainless)
02	2.5 litre fixed (anodised aluminium)
05	5 litre fixed (anodised aluminium)
10	10 litre fixed (316 stainless)
20	20 litre fixed (316 stainless)
4E	4 litre fixed - 'Ergo' (316 stainless)



We are a long established ISO 9001:2015 certificated designer and manufacturer of hydraulic equipment. Full details of other products in our range are available from:

Sarum Hydraulics Limited
 Unit 1 Danebury Court, Salisbury, SP4 6EB, UK
 Tel: 44(0)1722 328388 Fax: 44(0)1722 414307
 email: pumpsales@sarum-hydraulics.co.uk
 www.sarum-hydraulics.co.uk



SARUM
 HYDRAULICS
 Designers & Manufacturers of Micropac® Hydraulics

We invest heavily and continuously in product development. Specifications are therefore liable to change without prior notification.
 ®Micropac is a Registered Trade Mark of Sarum Hydraulics