



Micropac® TM series C10-2 Cavity Cartridge Hydraulic Hand Pump

Made in England 



TYPICAL APPLICATION:

USE IN LUBRICATION SYSTEMS

EMERGENCY RELEASE OF MACHINERY BRAKING

PILOT SUPPLY FOR EMERGENCY LOWERING OF MOBILE ELEVATING PLATFORMS



Direct acting hand pump for low pressure hydraulic applications

FEATURES

- Mounts directly into industry standard cavity
- Cost effective- no interconnecting pipework
- Compatible for use with mineral oil
- Simple direct action with spring loaded return
- Single acting operation - pumps on down stroke
- Hardened steel piston rod for long life
- British designed and manufactured
- Robust steel & aluminium construction
- Displacement 1.3cc/ double stroke, 50bar max.
- Nitrile/ PTFE sealing; other options available
- Operating temperature range -20°C to 80°C
- Pressure connection on nose; inlet on annulus
- Inlet and outlet check valves built in
- Factory support for application and use

INSTALLATION & MAINTENANCE

APPLICATION

The unit is suitable for applications requiring low pressure manual generation of hydraulic power e.g. lubrication systems, machine braking systems, pilot supply for emergency lowering of mobile elevating platforms.

Operation: on the up stroke, fluid is drawn in through the pump inlet check valve in the annulus, in alignment with the side port in the manifold cavity. On the down stroke the inlet check valve closes and fluid is displaced out through the nose port, in alignment with the port in the cavity base. An outlet check valve within the pump body maintains system pressure.

This unit displaces 1.3cc per double stroke up to 50 bar and is directly actuated by pushing the knob actuator on the end of the piston rod down; actuator return to 'up' position is spring loaded.

Hydraulic sealing is nitrile and PTFE; fluorocarbon and ethylene propylene options are available, please discuss your application with the factory.

The unit may be universal mounted e.g. vertical, horizontal.

MATERIALS

Zinc plated steel pump body, aluminium alloy bearing, hardened steel piston rod, polyamide knob actuator. PTFE and nitrile elastomer sealing.

SAFETY

This unit is a component forming part of a hydraulic pressure system. If forming part of a permanent installation, the system should be designed, operated and maintained in accordance with statutory and regulatory requirements, and other relevant instructions.

A risk assessment covering safe installation, operation and maintenance should always be carried out prior to use.

Under the EU Pressure Equipment Directive (PED) 2014/68/EU and the UK Pressure Systems (Safety) Regulations 2016, the unit is not required to be CE or UKCA marked.

SPECIFICATION

Displacement/ double stroke: 1.3cc

Max. operating pressure: 50 bar

Max. flow: 52cc/min (typical)

Nom. operating hand load: 355N @ 50 bar

INSTALLATION

Suitable for manifold mounting into an industry standard cavity type C10-2 (2 port, 7/8"-14UNF thread) with tank on side port, outlet to cavity base port.

Ensure pump body seals are lubricated and required cleanliness is maintained. The pump body must be carefully inserted on the axis of the cavity and screwed into the cavity.

Recommended tightening torque when screwing pump body into cavity: 80-90 Nm.

CONNECTIONS

Through cavity. As with any hand pump, the inlet line back to tank should be kept as short and unobstructed as possible for optimum performance.

Note; **this unit does not feature an inlet strainer.** The hydraulic media must be clean and free from any particulates; a 20 micron filter on the suction line is recommended.

COMMISSIONING

The pump should be operated after installation to leak test and bleed the hydraulic circuit. Failure to do so may result in reduced pump displacement and a spongy action.

MAINTENANCE

Maintenance operations should only be carried out by a competent service engineer.

The inlet and outlet check valves are easily serviced. Seals are replaced using standard tools. Service kits are available.

The external thread, seals and check valve components should all be protected from damage during storage or maintenance.

Check that the outlet check valve has not been damaged or dislodged during maintenance.

Sarum Hydraulics Ltd also offer a servicing facility; please advise before returning the unit to us.

Compatibility: mineral oil

Ambient operating temperature range: -20 to 40°C

Media operating temperature range: -35 to 80°C

Weight: 0.4kg (approx.)

DIMENSIONS

DIMENSIONS IN mm

FOR FURTHER DETAIL,
SEE INSTALLATION DRAWINGS;
CONTACT FACTORY OR
DOWNLOAD FROM WEBSITE

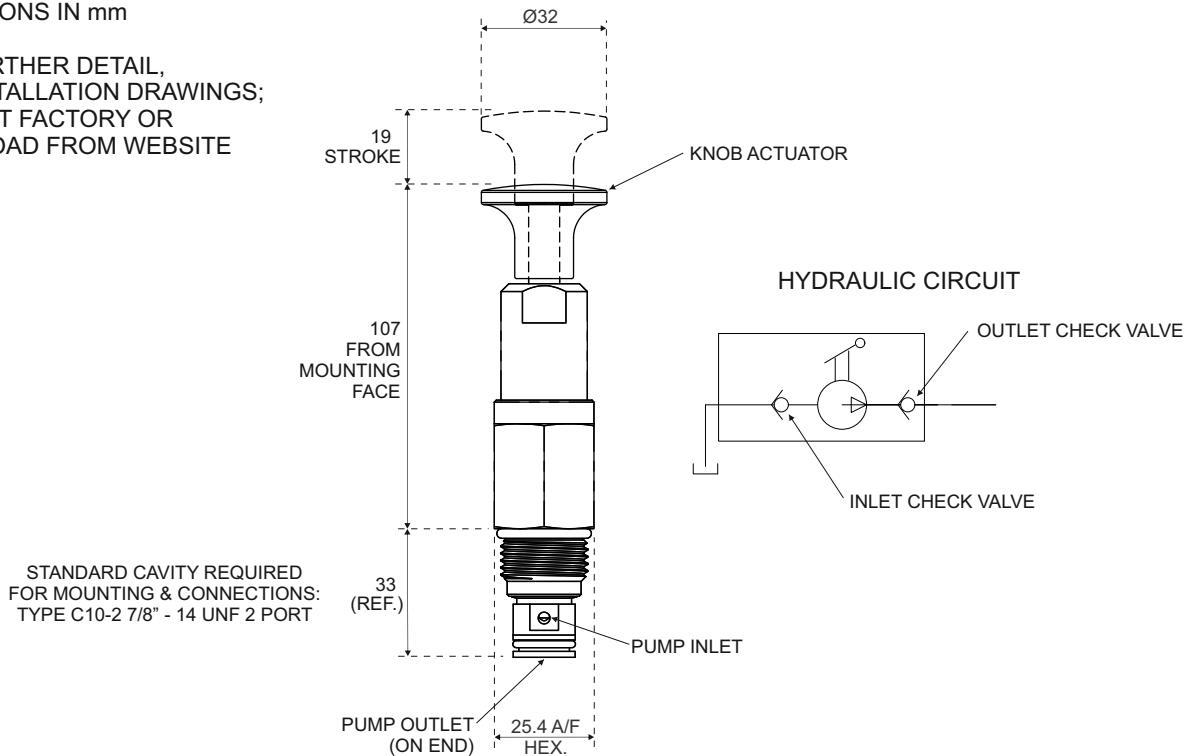

ORDERING CODE

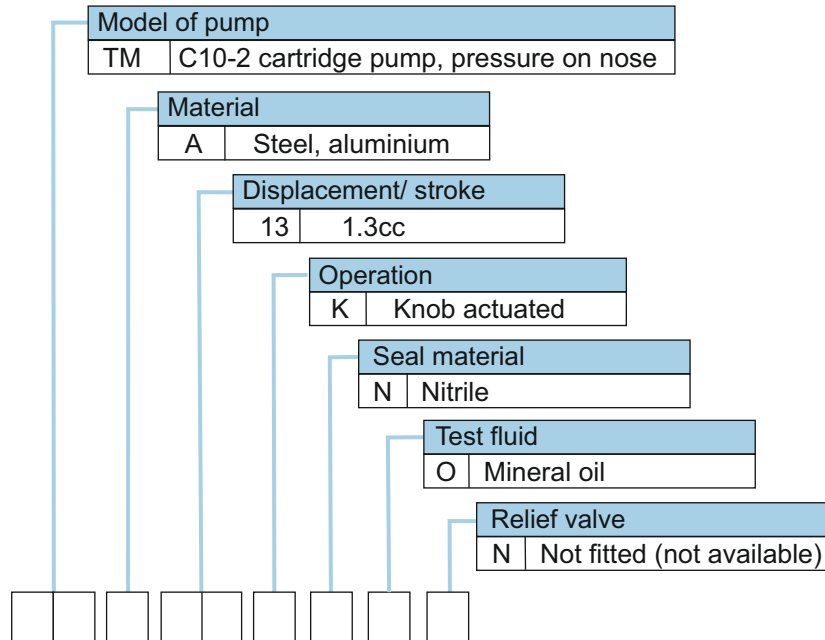

We are a long established ISO 9001:2015 certificated designer and manufacturer of hydraulic equipment. Full details of other products in our range are available from:

Sarum Hydraulics Limited
 Unit 1 Danebury Court, Salisbury, SP4 6EB, UK
 Tel: 44(0)1722 328388 Fax: 44(0)1722 414307
 email: pumpsales@sarum-hydraulics.co.uk
 www.sarum-hydraulics.co.uk



SARUM
 HYDRAULICS
 Designers & Manufacturers of Micropac® Hydraulics

We invest heavily and continuously in product development. Specifications are therefore liable to change without prior notification.
 ®Micropac is a Registered Trade Mark of Sarum Hydraulics