



Micropac stainless steel heavy duty turntable trolley

Micropac turntable trolley with flat bed load platform, max. load capacity 500kg



Suitable for offshore, process, chemical and food industry applications. Also suitable for industrial use; flat bed ideal for equipment mounting.

FEATURES

- 316 grade stainless steel welded construction
- Flat bed load platform for universal application
- Standard deck height 380mm; spill lip optional
- 200mm polypropylene wheels with rubber tyres
- Sturdy T bar pulling handle with grips
- Front axle mounted polymer turntable bearing
- Highly manoeuvrable with tight turning circle
- Auto-braking when handle is in up position
- 1200mm x 600mm or 760mm x 600mm platform
- Heavy duty - maximum 500kg load capacity
- Rugged- designed for punishing environments
- Suitable for scrub and wash down applications
- Quality British manufacture - 3 year warranty
- Ideal for equipment mounting onto platform
- Factory support for product and application
- 304 grade stainless model made to order
- Enquire about other sizes, heights or wheels
- Contact us for ATEX and IECEx applications

SPECIFICATION & DIMENSIONS

APPLICATION

For use only on even terrain. Maximum load 500kg; load to be centred on load platform and not to overhang edges. Note; the platform design is smooth and without any edge retaining lip- give consideration to load retention where relevant. A retaining anti-spill lip is an option. Consult the factory.

CONSTRUCTION

Braced and reinforced all welded 316 grade (optional 304 grade) stainless steel chassis. Turntable mounted on front axle, supported by polymer bearing. Welded T bar pull handle attached, with braking mechanism acting on both front wheels. Low rolling resistance polypropylene wheels with thermoplastic rubber elastomer (TPE) bonded tyres for low noise, comfort and good floor preservation. Metallic wheels with roller bearings are an option, but are not corrosion resistant.

Load platform may be drilled for mounting of equipment.

USE

The handle rests in the up position. To pull and manoeuvre the trolley, lower the handle to a comfortable height. Observe manual handling training when pushing and pulling; do not overload or speed. Trolley is braked in the handle-up position.

SAFETY

A risk assessment covering safe application and use, and training of personnel, should always be carried out prior to use.

INSPECTION & MAINTENANCE

The trolley is not designed for lifting and as such does not require periodic inspection. It is otherwise maintenance free.

ORDERING CODE

MY---

PR=polypropylene/rubber wheels
 316=316 grade stainless steel
 304=304 grade stainless steel
 1206=1200mm x 600mm platform
 0806=760mm x 600mm platform

WEIGHT (EMPTY):
 1200mm x 600mm platform model 35kg
 760mm x 600mm platform model 25kg

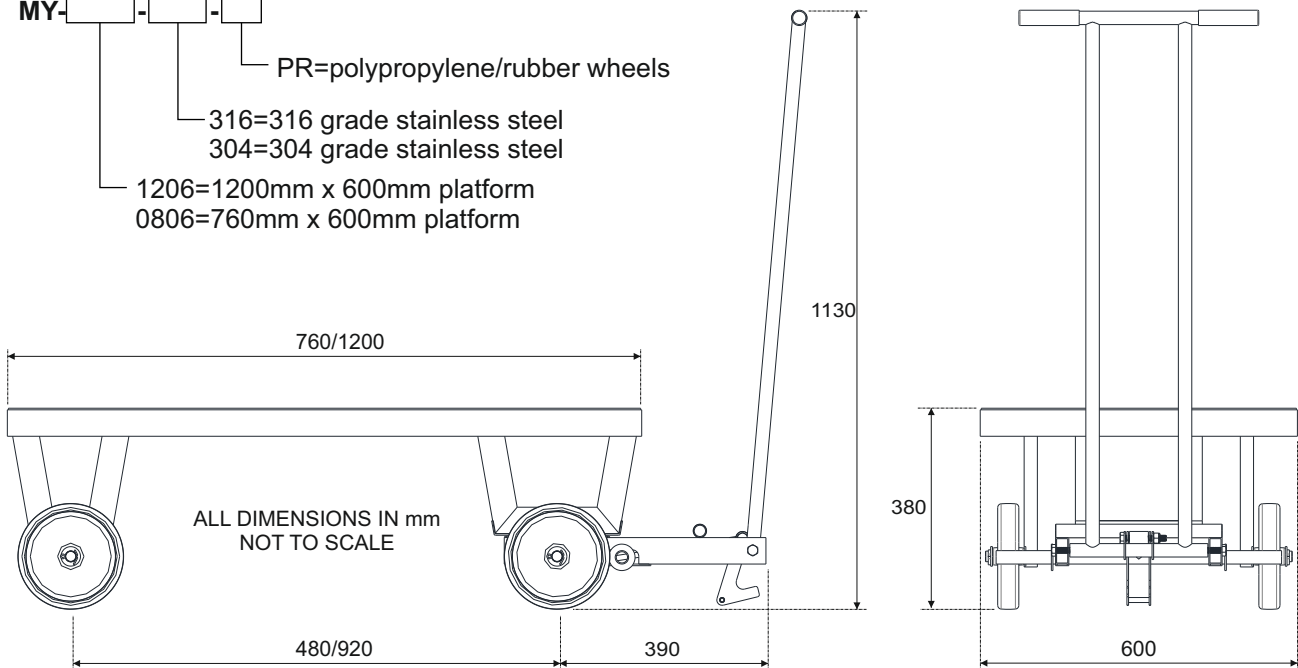

CE marking: this product is not within the scope of The Machinery Directive 2006/42/EC or any other relevant Directive. As such, it does not carry the CE marking.

Sarum Hydraulics are an ISO 9001:2015 registered company with over 35 years experience in design and manufacture of hydraulic equipment. Call us, email us or visit our website to find out more about our extensive product range. Enquiries are welcomed for bespoke solutions.

Sarum Hydraulics Limited
 Unit 1 Danebury Court, Salisbury, SP4 6EB, UK
 Tel: 44(0)1722 328388 Fax: 44(0)1722 414307
 email: pumpsales@sarum-hydraulics.co.uk
www.sarum-hydraulics.co.uk



SARUM
HYDRAULICS
 Designers & Manufacturers of Micropac® Hydraulics

We invest heavily and continuously in product development. Specifications are therefore liable to change without prior notification.
 ©Micropac is a Registered Trade Mark of Sarum Hydraulics